

WWW.SJJIF.ORG

**SJJIF**



SPORT JIU-JITSU INTERNATIONAL FEDERATION

# **RULEBOOK**

RULES & REGULATIONS

# Sport Jiu-Jitsu International Federation Rules and Regulations

## Table of Contents

Article 1	Definition of Brazilian Jiu-Jitsu
Article 2	Jiu-Jitsu Community
Article 3	Federation Membership
Article 4	SJJIF Competition Calendar
Article 5	Competition
Article 6	Sanctioned Events
Article 7	SJJIF Software and Database
Article 8	Doping Control
Article 9	Tournament Floor Plan and Layout
Article 10	SJJIF Head Committee, Staff, and Volunteer Responsibilities
Article 11	Awards Ceremony
Article 12	Tournament Prizes and Recognitions
Article 13	Tournament Team Points
Article 14	Country Team Points
Article 15	SJJIF Individual Ranking
Article 16	SJJIF National, Professor, and Team Ranking
Article 17	Code of Conduct
Article 18	Violations and Discipline
Article 19	Event Operating Rules
Article 20	Registration
Article 21	Qualifications
Article 22	Team Transfers
Article 23	Nationality
Article 24	Gender Control
Article 25	Sports Integrity
Article 26	Matchmaking
Article 27	Brackets
Article 28	Age Divisions
Article 29	Kid Belt System
Article 30	Juvenile & Adult Belt System
Article 31	Black Belt System
Article 32	Belt Integrity
Article 33	Match Times
Article 34	Weight Divisions
Article 35	Uniform Requirements
Article 36	Reporting for Competition
Article 37	Basic Principles for Uniform Inspectors
Article 38	Basic Principles for Referees
Article 39	Grading of Referee Performance
Article 40	Gestures for Referees
Article 41	Conclusion to Matches
Article 42	The Point System
Article 43	Minor Fouls, Stalling, and Penalty Points
Article 44	Legal & Illegal Techniques & Submissions
Article 45	Serious Fouls & Disqualification
Article 46	Out of Bounds & "Sudden Death" Overtime
Article 47	Medical Timeouts and Injury Procedures
Article 48	Visually or Physically Impaired Competitors in Traditional Competition
Article 49	3 Referees Format
Article 50	Adapted Jiu-Jitsu & Special Events
Article 51	Protests



## Preamble

The primary goal of the Sport Jiu-Jitsu International Federation is to unify and organize existing Sport Jiu-Jitsu, Brazilian Jiu-Jitsu, and Jiu-Jitsu national and/or territorial federations that share the vision of reaching Olympic greatness while preserving the unique history, culture, philosophy, and lineage of the sport.

SJJIF believes that together, the SJJIF with its National Federations and members will continue to develop a growing network of likeminded individuals who envision greater opportunities for athletes and Brazilian Jiu-Jitsu.

Therefore, the Sport Jiu-Jitsu International Federation aims to organize the sport of Brazilian Jiu-Jitsu and its federations, establishing one common set of rules that will enable the sport to grow into a recognized Olympic sport. The SJJIF also strives towards hosting tournaments that are enjoyable, fair to all competitors regardless of affiliation, race, gender or nationality, and rewarding for all participants.

Each federation under the SJJIF is responsible for hosting competitions that will rank athletes in their respective territories. SJJIF will organize the annual SJJIF World Jiu-Jitsu Championship in both GI and No GI, in collaboration with representative federations.

SJJIF will provide organizational and promotional support to all member federations and SJJIF sanctioned events, as appropriate. SJJIF also aims to adopt, implement, and promulgate the World Anti-Doping Agency Code.

The goal of this document is to delineate rules and to create equitable guidelines for coaches, athletes, patrons, and spectators to support the evolution and cohesion of Brazilian Jiu-Jitsu.



## History of Sport Jiu-Jitsu

Jiu-Jitsu is a multi-faceted method of self-defense and dynamic sport composed of techniques that work towards superior positioning in order to submit an opponent by applying force to a joint or to a chokehold. Technique is emphasized over strength to place an opponent in a controlled position or submission. During competitive matches, winning is achieved by earning points by placing the opponent in different positions or by forcing them to submit.

The Jiu-Jitsu of today is composed of many key factors that include the many ancient forms of combat that found its way to Brazil in the early 1900's through the Japanese migration into the country and the unique Brazilian culture that embraced the arts of fighting in its many forms. Its evolution a direct product of the contribution of many Brazilian families that dedicated themselves to the sport, integrating familial values, healthy lifestyle, and determination to prove the superiority of Jiu-Jitsu as a martial art.

On April 25, 1967, the Jiu-Jitsu Federation of Guanabara was founded in Rio de Janeiro, Brazil. The federation was established under the National Sports Confederation by five founding schools led by Hélio Gracie, Alvaro Barreto, Joao Alberto Barreto, Hécio Leal Binda and Oswaldo Baptista Fadda. Chaired by Hélio Gracie, the founding of the Jiu-Jitsu Federation of Guanabara was the first step in making Jiu-Jitsu a sport, and not only a form of self-defense or street fighting art. The art of jiu-jitsu began to have structure and organization, evident in the implementation of a belt system, age division, competition time, points, and legal techniques.

In June 1973, Jiu-Jitsu was legally recognized as a sport in Brazil and in December 1973, the Federation Jiu-Jitsu Guanabara organized their first championship, the "1º Torneio Oficial de Jiu-Jitsu do Brasil", hosted in Rio de Janeiro at the Athletic Association Bank of Brazil. This event marked the beginning of a new era for Jiu-Jitsu as a sport.

After the implementation of Jiu-Jitsu as a sport and its fast growth throughout Brazil, in 1980 Jiu-Jitsu began to expand and develop internationally. As a result of all founders, professors, representatives, and participants of the sport being Brazilian at that time, the name Brazilian Jiu-Jitsu was adopted.

By 2010, Jiu-Jitsu or Brazilian Jiu-Jitsu was a sport practiced and recognized worldwide, but it lacked an established federation that met the IOC requirements or that was recognized as a single international governing body for the sport. With this in mind and the main motivating factor, a group of Jiu-Jitsu professors and tournament organizers thought that it was time to invest and dedicate themselves to the unifying and growth of the sport and its community, thus founding the Sport Jiu-Jitsu International Federation.



## History of the Sport Jiu-Jitsu International Federation

Led by Professor João Silva, in June of 2012, the Sport Jiu-Jitsu International Federation (SJJIF) was founded by professors João Silva, Patricia Silva, Samuel Aschidamini, Edison Kagohara and Cleiber Maia with the primary goal of unifying and organizing existing Sport Jiu-Jitsu, Brazilian Jiu-Jitsu and Jiu-Jitsu National and/or territorial federations that shared the vision of reaching Olympic greatness while preserving the unique history, culture, philosophy and lineage of the sport.

These individuals realized the importance of organizing and structuring the sport of Jiu-Jitsu and understood that this would be a journey that would require time, dedication and the collaboration of everyone in the sport. It was understood among these individuals, that with the sport's evolution and growing popularity around the world, a unified body was necessary to prove that Jiu-Jitsu was a stand-alone sport that could gain recognition and admittance into the Olympic program as a competition event of the Olympic Games, Paralympic Games, Deaflympics and in all other games of the Olympic cycle.

SJJIF hosted its first international event, the SJJIF World Championship, on December 14 and 15 of 2013 at the Long Beach Pyramid in Long Beach, California USA. The SJJIF has grown tremendously since its founding and it has already had sanctioned events and federations in North America, South America, Asia, Europe, Africa and Oceania.

Establishing one set of governing rules, the SJJIF is continuing to develop or unify existing federations, creating a growing network of likeminded members who envision greater opportunities for athletes and Brazilian Jiu-Jitsu. Together, the sport will continue to be organized under one set of governing rules, offer rules courses to educate practitioners of the sport in its rules, host high quality and fair competitions in GI and No GI, and rank athletes internationally and in their respective territories.

The SJJIF has further developed the sport by providing National Federations with the opportunity to be part of the true international governing body of Brazilian Jiu-Jitsu, where their voice and vote directs the future of the SJJIF and sport. For the sport community the SJJIF has developed or assisted in the development of several programs and events that promote the importance of youth development, fair competition, respect, inclusion, equality, cooperation, peace, and friendship while also striving towards hosting tournaments that are enjoyable, fair, and rewarding for all participants.



## The Evolution of Sport Jiu-Jitsu Rules

Sport Jiu-Jitsu was developed to continue challenge and educate experienced Jiu-Jitsu practitioners, helping them refine the art of self-defense while preserving the essence, principles, and strategies of Brazilian Jiu-Jitsu. Competitors engage in sportsmanlike matches focused on acquiring a superior control position and submission in a efficient and effective way.

On April 25, 1967, Hélio Gracie—known as the father of Sport Jiu-Jitsu—founded the first Jiu-Jitsu federation, the Guanabara Jiu-Jitsu Federation, in Rio de Janeiro, Brazil.

With the formal establishment of rules, interaction among academies increased significantly. Over time, the rules evolved to reflect technical advancements and the growing diversity of techniques, driven by Brazilian creativity, natural abilities and the Jiu-Jitsu culture for adaptability, enriching and forming the Sport Jiu-Jitsu. Over time, the regulation of the rules became necessary to protect practitioners from serious injuries resulting from dangerous techniques, thus allowing the discipline to evolve becoming a safe and healthy sporting practice accessible to everyone.

### **The Evolution of the Sport Rules**

The original scoring system included:

- Takedown: 2 points
- Guard pass: 2 points
- Knee on the belly: 3 points
- Mount and Back: 4 points

As the sport evolved, adjustments were made:

- Guard pass increased to 3 points
- Knee on the belly reduced to 2 points

When positions were not fully completed, “advantages” were awarded. For example, an almost-completed mount would earn 4 advantages.

### **Combativity Rules**

Advantages were later removed and replaced with the concept of “combativity.” In tied matches, the winner was determined by which athlete showed greater initiative and aggression. This era also introduced the use of three referee flags to determine decisions.

### **Advantage Rules**

Advantages were reintroduced and became a major factor in match outcomes. Additional penalties and fouls were implemented to encourage more dynamic fights. Referee gestures were standardized to improve clarity for officials and spectators.



## Modern Rules

Advantages are still used in many non-SJJIF sanctioned events. However, they are subjective and often lead to ties, requiring referee decisions to determine winners. This subjectivity can create confusion, disputes, and perceived bias.

In 2005, the North American Brazilian Jiu-Jitsu Federation, under Professor João Silva, introduced a new rule system focused on fairness and clarity:

- No advantages
- Clear point-based scoring
- Overtime in case of a tie, continuing until points or submission
- Video review was also introduced to correct officiating errors and improve fairness.

The SJJIF adopted this system in 2012, hosting its first World Championship in 2013 in Long Beach, California.

In 2015, it was established that all rule changes must be approved through a formal voting process during the annual SJJIF General Assembly. National and continental federation leaders propose and vote on changes based on safety, fairness, transparency, and the continued development of the sport.

## What is Sport Jiu-Jitsu

Sport Jiu-Jitsu is a match between two competitors competing in a sportsmanlike manner. The objective is to win by submission (joint lock or chokehold) or by outscoring the opponent through superior positions.

The sport includes:

- Throws and takedowns
- Positional control
- Guard passes and sweeps
- Joint locks and chokeholds

Jiu-Jitsu is based on efficiency, leverage, and strategy, allowing a smaller, weaker individual to defend against a larger opponent.

## Competition Styles

- Gi Competition:  
Athletes wear a uniform (Gi) made of a cotton jacket, pants, and belt. The Gi allows for a wide range of grips and techniques.
- No-Gi Competition:  
Athletes wear rash guards and shorts. Grabbing clothing is not allowed, resulting in different gripping strategies.



Both styles are dynamic and feature a wide variety of techniques.

Matches begin with both competitors standing, bowing to the referee and each other as a sign of respect.

### **Match Conduct**

Athletes, referees, and coaches are expected to behave in a sportsmanlike manner. The referee starts the match by signaling and announcing “Fight” or “Combate.” Once grips are established, the match may transition to the ground.

### **Competition Area or Field of Play**

The competition area consists of:

- Minimum size: 21 x 21 feet mat area
- The Central Area is called Central fighting area
- The Outside borders of 1-meter is called safety area and surrounds the central area.

Together, these form the combat area. Additional to the safety area event organizer may use an additional safety area called escape area to protect the players from any movement that go beyond the safety area.

### **Principles of the Match**

The main objective is to force the opponent to submit (tap physically or verbally).

Competitors may:

- Submit from standing or ground position
- Use takedowns or guard pulling to get the match to the ground
- Progress through acquiring superior positions and or to achieve submission

Scoring rules:

- Takedown points are awarded immediately
- Superior ground positions must be stabilized for 3 seconds to be awarded points.
- Matches should reflect a progression of control leading to submission.

All official SJJIF Rules and Regulations can be found in this document.



## **Article 1          Definition of Brazilian Jiu-Jitsu**

- 1.1 Brazilian Jiu-Jitsu is a martial art, which is composed of techniques that are emphasized over strength to place an opponent in a controlled position or submission divided into GI and No GI divisions. The objective of the fight is to win. During competitive matches, two competitors of same age group, weight division, and belt rank fight against each other in a sportsmanlike competition adhering to the SJJIF rules. Winning is achieved either by earning points through placing the opponent in superior positions or forcing them to submit.

## **Article 2          Jiu-Jitsu Community**

- 2.1 Federations will connect directly with their communities, developing events where all Jiu-Jitsu practitioners are welcome to learn and share techniques with one another in a neutral and non-competitive environment that will promote the education of our sport, as well as develop friendships amongst our peers where athletes, professors, and federation join together for pure Jiu-Jitsu, regardless of team or associations.

## **Article 3          Federation Membership**

- 3.1 The international Olympic committee requires proof of participants in the sport and it is through SJJIF membership that the federation obtains accurate records of its participants.
- 3.2 All SJJIF Federations will work with the SJJIF membership ID card that is provided by the SJJIF.
- 3.3 Through SJJIF membership the federation is able to maintain an accurate record of each registered members' lineage, belt promotion, course participation, competition history, and ranking under one governing body.
- 3.4 The SJJIF reserves the right to contact the instructor of an applicant as well as other resources to ensure accuracy and veracity in the records of belt rankings of SJJIF members. Further membership information is available at [www.sjjif.org](http://www.sjjif.org).
- 3.5 SJJIF membership entitles an individual to an SJJIF ID card that recognizes their Jiu-Jitsu belt rank and citizenship. This card also contains the following membership benefits:
  - a) Member will have an SJJIF ID card and member number;
  - b) Will be listed as a current member under the SJJIF website;
  - c) Member will be part of a world ranking system;
  - d) Member will have access to list of results and fight records;
  - e) Member will be part of a tournament discount program;
  - f) Member will have complimentary spectator admission to any SJJIF tournament.

## **Article 4          SJJIF Competition Calendar**

- 4.1 The current SJJIF competition calendar can be found on the SJJIF website ([www.sjjif.org](http://www.sjjif.org)).
- 4.2 The SJJIF competition calendar and ranking year begins after the SJJIF World Jiu-Jitsu Championship and ends at the following SJJIF World Jiu-Jitsu Championship.



## Article 5 Competition

- 5.1 Competition is a great opportunity for participants to learn how to face challenges, building character and resilience through the challenges of competition.
- 5.2 All SJJIF competitions must use the SJJIF software and abide by the SJJIF Statutes & Bylaws and SJJIF Rulebook.
- 5.3 All SJJIF competitions must play their respective national anthem followed by the Brazilian national anthem during the opening ceremony.
- 5.4 All SJJIF federations must ensure that the SJJIF rules & regulations are upheld to promote fair and quality competition where hygiene, fair play and mutual respect is valued.
- 5.5 All SJJIF sanctioned competition results will contribute to the world ranking system.

## Article 6 Sanctioned Events

- 6.1 With the intention of creating a unified, balanced, and fair organization of events the SJJIF will assist in establishing a unified calendar and set of rules that will assist in ensuring that each event is successful. All SJJIF sanctioned events will be posted in the SJJIF calendar for everyone to see and avoid double booking. The following procedures will be followed:
  - a) All SJJIF federations and/or organizations will be required to submit an event application with a minimum of 60 days prior to the event date in order to receive approval.
  - b) No sanctioned event shall be conducted unless an event application has been submitted and approved by the SJJIF.
  - c) All sanctioned events must be conducted in a professional venue (no BJJ academy gyms or equivalent are permitted to host events).
  - d) A sanctioned event cannot be transferred to another organization, unless cleared and approved by the SJJIF.
  - e) Event Sponsorship must be approved by the SJJIF.
  - f) No sanction will be issued for any event where the word "World", "Olympic" or any derivative thereof is used in any advertisements or notice in connection with the event.
  - g) All events will be registered under the SJJIF calendar and there will be the following proximity regulations:
    - i. There must be a 3-week wait period between uses of the venue of a prior tournament.
    - ii. No two events will be allowed in the same city on the same date.
    - iii. Sanctioned events may be hosted on the same day with a minimum distance of 200 miles.
- 6.2 SJJIF Sanctioned Competitions must follow SJJIF quality standards on events for the following:
  - a) Mat areas
  - b) Rules & regulations
  - c) Banners
  - d) Marketing material
  - e) Trained staff
  - f) SJJIF certified referees
  - g) Venue
  - h) T-shirts



- i) Podium
- j) Medals

k) Trophy

- 6.3 SJJIF Sanctioned Competitions must comply with any regulations of health and safety put forth by the region they represent.
- 6.4 SJJIF Sanctioned Competitions organizers must pay all expenses for a SJJIF representative to be present the day of the event to assist and/or inspect the implementation of the SJJIF rules and regulations.
- 6.5 SJJIF Sanctioned Competitions organizers should encourage individuals, academies, and teams to register with the SJJIF to be part of the SJJIF Ranking System.
- 6.6 SJJIF Sanctioned Competitions organizers should aim to adopt and implement the Anti-Doping Agency Code.

#### **Article 7 SJJIF Software and Database**

- 7.1 The SJJIF has developed software designed to provide the federation and its members with elite sport organization. The software will create an international database that keeps precise records of its members, number of countries involved in the sport, member nationality, member lineage, member belt history, member ranking, member competition record, etc.
- 7.2 All SJJIF sanctioned federations and events will use the SJJIF Software to ensure accurate data collection and access to database information.
- 7.3 The SJJIF Software will allow individual members to have increased accessibility to the organization, events, and rankings.

#### **Article 8 Doping Control**

- 8.1 Sport Jiu-Jitsu International Federation (SJJIF) embraces the concept of fair play as a fundamental value integral to sport. Sport without doping is a key component of fair play that demonstrates respect, integrity, and honesty to the sport, oneself, and others.
- 8.2 SJJIF is not yet a WADA Code signatory, but in our recognition of the importance of fair play and sport without doping, SJJIF is in full support of the World Anti-Doping Agency (WADA) mission to lead a collaborative worldwide movement for doping free sport.
- 8.3 SJJIF is developing a SJJIF Anti-Doping Policy that adheres to WADA's anti-doping policies, including arranging a doping control process and abiding by the WADA Prohibited List.
- 8.4 SJJIF aims to implement the doping control procedures of the SJJIF Anti-Doping Policy and enforce restrictions and/or sanctions resulting from an athlete found to have a positive test and who has undergone the adjudication process. The adjudication process shall provide athletes with a full due process and confidentiality while the case is pending. For the most recent updates on the SJJIF Anti-Doping Policy visit [www.sjjif.org](http://www.sjjif.org).



## Article 9 Tournament Floor Plan and Layout

- 9.1 The tournament floor plan and layout for a competition shall be composed of one or more match areas, score tables, a warm-up area, a uniform inspection area, a weigh-in area, a medic area, a center table, an awards area, and an announcer who directs the event and who must also be a competent & recognized authority.
- 9.2 The matches must be conducted on the mat areas, surrounded by all the supporting assistants, referees, time keepers, inspectors, medics, security personnel, and a referee director appointed by the coordinators who has the power to discipline any unethical conduct of coaches, professors, referees, athletes, or other assistants that might interfere with the progress of the event. The guidelines for the mat area/field of play are as follows:
- Mat areas are composed of a combat area and an outlying safety area distinguished from each other by different colors. Each mat area must be composed of a minimum of 49 square meters with 25 square meters comprising the combat area and 24 square meters comprising the safety area surrounding the combat area.
  - Mat areas should be numbered so that competitors may be directed to it by its respective number. The mat areas are numbered from left to right from the side where the main table is located.

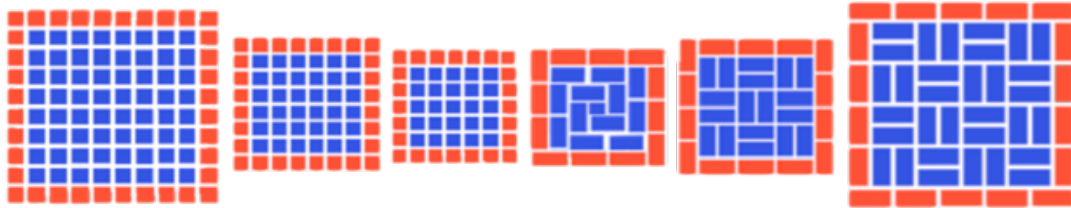

- 9.3 Each designated mat area will have an assigned score table that will coordinate and direct assigned tasks during the competition. The guidelines for the score tables are as follows:

- Parallel to the scoring table, chairs will be positioned for the referees.
- Chairs and tables are to be placed strategically to the side of the competition area for the best assessment of each match.
- For each designated mat area there will either be two scoreboards, indicating the score horizontally, or a single monitor, which will have colored scores to differentiate athletes.
- The scoreboards or monitor will be situated on the assigned mat area table, easily viewed by the referee, officials, and spectators.
- Stopwatches or a similar digital system will be used for keeping track of the duration of the matches and the reserve time.



- 9.4 The warm up/bullpen area is a cornered-off area adjacent to the competition area, for the exclusive use of athletes. The guidelines for the warm up/bullpen area are as follows:
- The championship organizing committee shall summon the athletes of each division to the warm-up area as pre-determined by the event timetable.
  - It is at this location and only at this location that Ring Coordinators or Runners will direct athletes to the match areas.
- 9.5 The weigh-in and GI and No GI inspection area is where athletes will be weighed in and uniforms shall undergo an inspection for size, patch placement, hygiene, belt, and overall condition. The weigh-in area should include at least one scale with which to determine athlete weight. For additional information see Article 34 – 37.
- It is up to the event organizing committee whether a scale will be provided for athletes to check their weight prior to the official weigh-in.
- 9.6 The main table should be placed at a location central to all mat areas to support bracket distribution to Ring Coordinators and result diagrams will be drawn up in order to award athletes their medals.
- 9.7 The podium is where the top 3 competitors and teams are awarded their medals and trophies. The guidelines for the podium are as follows:
- The podium should have three levels: the highest level for first-place athletes; the second highest (on the right of first-place) for second-place athletes; and the lowest (on the left of the first-place) for third-place athletes.
  - The podium must have a backdrop behind it where the tournament name and sponsors are displayed.
- 9.8 The medic area should be placed at a location near all mat areas, with easy visibility, to support immediate medical attention when needed.

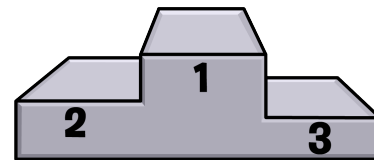

## Article 10 SJJIF Head Committee, Staff, and Volunteer Responsibilities

- 10.1 All members of the SJJIF Head Committee, staff, and volunteers are a direct reflection of the SJJIF and must be trained and/or approved by the SJJIF as well as follow the Code of Conduct identified in the SJJIF Rulebook Article 17.
- 10.2 All members are expected to conduct themselves in a respectful manner with professional behavior that reflects pride in partaking in a successful and efficient event. Any person that fails to follow or maintain the image of the SJJIF is subject to have membership, certificate, and/or approval suspended or revoked. General responsibilities are as follows:
- Report to the event at least one-half hour (30 minutes) prior to the event;
  - Dress appropriately and in uniform;
  - Must be focused and engaged in handling duties efficiently and accurately;



- d) Maintain a professional demeanor;
  - e) It is prohibited to issue instructions to an athlete in the competition area. Support can be shown for athletes by stepping outside the competition area and standing behind the spectator barricade.
- 10.3 **Tournament Host:** The Tournament Host oversees the overall planning of the event and makes final decisions regarding any issues pertaining to event organization and progress. This person has supervisory authority over all phases of the local tournament operation, attends necessary meetings, advises, directs, and makes assignments where necessary. Ensures that the event is held in a good venue, has all necessary equipment and technology, and that insurance is current. Works adamantly to ensure that the event stays on-schedule and is efficiently executed. A major responsibility of the Tournament Host is to contact SJJIF for all matters to ensure that the event is successful and upholds the SJJIF standards.
- 10.4 **Director of Promotion:** The Director of Promotion is responsible for promoting the event to local gyms, academies, and organizations. Promotion of events will encompass the use of social media, local media (newspapers, magazines, and radio stations), mailers, posters, flyers, newsletters, and invitations. Information on dates, cost, and registration should be visible or accessible. The Director of Promotion should also strive to obtain publicity coverage of the event and is responsible for having an official event photographer present on day(s) of the tournament.
- 10.5 **Weigh-In Officials:** Weigh-In Officials are responsible for competitor weigh-ins and ensuring that each competitor is the proper weight for the registered division, for both a GI or No GI event. The competitor is responsible to fall within the registered division weight limit and know their weight with GI or No GI uniform. If the competitor does not meet weight requirements they are automatically disqualified. Weigh-In Officials have the autonomy to determine disqualification.
- 10.6 **Main Table Coordinator:** The Main Table Coordinator oversees all the work performed by the main table assistants, ring coordinators, and runners to ensure proper and accurate progression of brackets. If the tournament is not using an electronic bracket system, this individual is responsible for holding on to and distributing paper brackets to the ring coordinator.
- 10.7 **Main Table Assistants:** Main Table Assistants are responsible for reviewing and updating bracket results provided by the ring coordinators. All systems must be operating properly, including computer and printer, and brackets kept in case of a discrepancy.
- 10.8 **Bracket Coordinator/Matchmaker:** The Bracket Coordinator/Matchmaker coordinates brackets prior to an event to create un-biased and fair matches, adheres to bracket procedures identified in the SJJIF Rulebook Article 27.1-27.18, and ensures that they are accurately followed. If there are any changes, the Bracket Coordinator/Matchmaker



must contact the competitor and professors (if competitor is a child, contact parents and professors) regarding any changes or updates.

- 10.9 **Score Keeper/Table Official:** The Score Keeper/Table Official must be completely focused during each match to accurately record points and penalties (negative points) signaled by the referee, make sure that points are being displayed on the scoreboard, keep match time, and announce the end of the match using a whistle.
- 10.10 **Uniform Inspectors:** Uniform Inspectors are responsible for using the SJJIF measuring tool to ensure that competitor uniform, whether it is GI or No GI, conforms to the SJJIF uniform regulation identified in the SJJIF Rulebook Article 35.1-35.13.
- 10.11 **Tournament Security:** Tournament Security guards assist in keeping order of events and ensuring spectator and competitor safety. Tournament Security guards are responsible for performing constant event walk-throughs to ensure that event main entrance and exit points are not blocked and that other points of entry and exit are closed.
- 10.12 **Front Table/Check-in:** There should be a minimum of two (2) people stationed at the Front Table/Check-in area. Responsibilities are to greet public, communicate spectator fees, collect fees, and stamp hand of each person that has paid for entrance to tournament as a spectator, check-in competitors, check ID, instruct them to bull-pen/warm-up areas, and address any questions that can be handled by front end personnel. These individuals are to ensure that the cash box is locked and money accounted for at the end of each tournament day.
- 10.13 **Ring Coordinator\*:** Ring Coordinators receive brackets from the Main Table, summon competitors to the warm-up area, check SJJIF IDs, direct competitors to the GI Inspector, ensure weigh-in before the first match, direct competitors to the match area, and follow matches accurately to record results in the bracket. After a bracket has come to a close, the Ring Coordinator returns the bracket to the Main Table.
- 10.14 **Runner\*:** Runners are responsible for supporting the Ring Coordinator with their duties.

*\*Ring Coordinator, Runner, or Weigh-In Inspectors will call for competitors prior to their matches up to three times at warm up area/bull pen, if competitor is non-responsive at that point, they will be called out via the PA system and will then have 5 minutes to report to Ring Coordinator, Runner, or Weigh-In Inspectors. If competitor does not report within the 5-minute mark they will be subject to disqualification.*

- 10.15 **Awards Team:** The Awards Team is responsible for having medals and trophies displayed and efficiently awarding medals which includes calling and announcing winners to the podium, setting competitors in place on the podium that is composed of three levels each labeled under 1<sup>st</sup>, 2<sup>nd</sup>, or 3<sup>rd</sup>, and placing medals according to placement.



- 10.16 **M.C./Announcer:** The M.C./Announcer is responsible for the welcome/introduction speech, assists in calling out divisions for weigh-in or check-in, makes announcements throughout the day regarding matches, winners, future events, sponsors, Facebook or twitter page, and general SJJIF information.
- 10.17 **Media/Photographer:** The Media/Photographer(s) are responsible for event coverage and are required to make all media available to SJJIF. Individuals seeking a SJJIF Press Pass should represent a social media company, magazine, or local newspaper and should acquire SJJIF approval three (3) weeks prior to the event to have access inside the competition area. Media/Photographer(s) shall not interfere with tournament procedures, matches, and/or distract competitors during competition.
- 10.18 **Medical Representatives:** Medical Representatives must be appropriately certified to handle injuries that may occur to athletes during competition. Individual must follow proper protocol in cleaning up and properly disposing of bodily fluids.
- 10.19 **Referee Director:** The Referee Director has supervisory authority over referees and is responsible for ensuring proper training of referees, including knowledge and understanding of the SJJIF rules and policies, selecting SJJIF certified referees for events, and during an event is responsible for overseeing referee decisions, quality, and fair play. The Referee Director is responsible for holding a pre and post event meeting with referees to review referee roles in competition and to discuss any concerns that occurred during the specific event. The Referee Director guides and issues a technical evaluation of the referees at the end of each competition. In some cases, and upon request, the Referee Director will review details or footage of a specific match and can overturn the central referee's decision as identified in the SJJIF Rulebook Article 51.1-51.2.
- 10.20 **Referee:** The referee has one of the most important roles in a tournament and is responsible for judging each match fairly based on the SJJIF rules of competition and declaring the appropriate winner. Only a Referee Director can overturn a referee decision after reviewing details or footage of a specific match. For further details on referee principles and procedures see Article 38.1-38.11

## Article 11 Awards Ceremony

- 11.1 Athletes must attend the medal ceremony wearing their SJJIF approved uniform.
- 11.2 Each athlete who has won a medal must be present at the ceremony and receive the medal personally. An athlete who is absent from the awards ceremony without a good cause will forfeit his/her medal. An athlete who refuses to attend the medal podium ceremony due to poor sportsmanship will immediately be disqualified from that division, consequently not earning points for his/her team and/or qualifying for the open weight division, if applicable.
- 11.3 It is strictly prohibited for athletes on the podium to do any disrespectful or provocative demonstration with religious, political, personal or commercial



connotation. It is prohibited for athletes to wear a cap or any head covering unless deemed necessary.

- 11.4 Athletes must stand at attention throughout the entire national anthem being played for the 1<sup>st</sup> place athlete.

## **Article 12 Tournament Prizes and Recognitions**

- 12.1 SJJIF sanctioned tournaments shall award medals to the top 3 adult competitors of each belt, age group, and weight division.
- 12.2 SJJIF sanctioned tournaments shall award medals to the top 3 kid competitors of each belt, age group, and weight division.
- 12.3 Official standing of each division shall be as follows:
- a) 1st place (Gold medalist): winner of the final contest;
  - b) 2nd place (Silver medalist): loser of the final contest;
  - c) 3rd place (Bronze medalists): winners of the finals of repechage.
- 12.4 SJJIF sanctioned tournaments may award kid competitors who did not place in the Top 3 with a participation medal.
- 12.5 SJJIF sanctioned tournaments shall award team trophies to the top 3 Adult teams and top 3 Kid teams.
- 12.6 SJJIF shall award the top 3 teams for each Kid and Adult teams in GI and No GI with Team of the Year trophies at the annual SJJIF World Jiu-Jitsu Championship that marks the end of the SJJIF competition year. The top 3 teams will be based on the accumulated points from all SJJIF sanctioned events during the respective competition year. For details on team ranking point system see Article 16.

## **Article 13 Tournament Team Points**

- 13.1 Academy/Team affiliation guidelines are as follows:
- a) Competitors are required to identify their team at registration so that tournament organizers can keep accurate track of team points.
  - b) Teams will be recognized by the names athletes list as their recognized Academy/Team.
  - c) All Athletes who register giving the same name for their Academy/Team will be recognized as a member of that team for that competition and will contribute to that team's points.
  - d) No athlete or coach may change the team they are registered for after the check date has passed.
- 13.2 Tournament team points are based on the accumulation of all gold, silver and bronze medals earned by all competitors representing that particular team in that specific tournament. Points accumulated for medals earned will be based on the point structure in this section. For each team, separate scores will be kept track of as follows:
- a) Kid Team Points – for all divisions from Kid 1 through Kid 6.



- b) Adult Team Points – for all divisions from Juvenile 16-17, Adult 18, and Master 30 through Master 61.
- c) Tournaments with less than one thousand competitors – Academy/Team will accumulate 7 points for Gold, 3 points for Silver, and 1 point for Bronze for each placed competitor.
- d) Tournaments with over one thousand competitors – Academy/Team will accumulate 14 points for Gold, 6 points for Silver, and 2 for Bronze for each placed competitor.
- e) The SJJIF World Jiu-Jitsu Championship – Academy/Team will accumulate 21 points for Gold, 9 points for Silver, and 3 points for Bronze for each placed competitor.
- f) Points from divisions where only one athlete is signed up will not count toward team points.
- g) If there is a draw in tournament team points, the winner will be decided by the largest number of gold medals received. In the event that there is a continued draw, the winner will be decided by the largest number of silver medals received. In the event that there is a continued draw, the winner will be decided by the largest number of bronze medals received.
- h) In the event that there is a continued draw after the procedures identified in Article 13.2.g, the winner will be decided by the medal count of the highest belt.

## Article 14 Country Team Points

- 14.1 Competitors are required to identify their nationality/country of origin at registration so that tournament organizers can keep track of the Country Team points. Country Teams will be recognized by the nation/country athletes list as their recognized nationality/country of origin at registration. All competitors identifying the same nationality/country of origin will accumulate points for that particular country. Points accumulated for medals earned will be based on the point structure in this section. For each team, separate scores will be kept track of as follows:
- a) Kid Team Points – for all divisions from Kid 1 through Kid 6.
  - b) Adult Team Points – for all divisions from Juvenile 16-17, Adult 18, and Master 30 through Master 61.
  - c) Athletes who place in a division in a tournament will accumulate points for their country team based on the medal count of most Gold, then Silver, and then Bronze for each placed competitor.
  - d) No athlete or coach may change the country team they are registered for after the check date has passed.



**Article 15 SJJIF Individual Ranking**

- 15.1 SJJIF Ranking is how the SJJIF ranks the top competitors in the sport.
- 15.2 The SJJIF World Jiu-Jitsu Championship is the final competition for SJJIF rankings.
- 15.3 Individual competitor ranking is based and divided by the individual's belt, age group, and weight division. Guidelines for individual ranking are as follows:
  - a) Ranking points will not be transferred from one belt rank to another.
  - b) Ranking points will not be transferred from one age division to another.
  - c) Ranking points are divided between GI and No GI events.
- 15.4 **Individual Ranking** is based on the following points system and will be calculated as follows:

Tournaments with less than one thousand (<1000) competitors		
7 points for 1 <sup>st</sup> place	3 points for 2 <sup>nd</sup> place	1 point for 3rd Place
Tournaments with over one thousand (>1000) competitors		
14 points for 1 <sup>st</sup> place	6 points for 2 <sup>nd</sup> place	2 points for 3rd Place
The SJJIF Worlds Tournament triples the awarded points		
21 points for 1 <sup>st</sup> place	9 points for 2 <sup>nd</sup> place	3 points for 3rd Place
a. 1 <sup>st</sup> place with 1 fight 1 <sup>st</sup> place points X 1.0	a. 2 <sup>nd</sup> place with 1 fight 2 <sup>nd</sup> place points X 1.0	a. 3rd Place with 1 fights 3rd Place points X 1.0
b. 1 <sup>st</sup> place with 2 fights 1 <sup>st</sup> place points X 1.1	b. 2 <sup>nd</sup> place with 2 fights 2 <sup>nd</sup> place points X 1.1	b. 3rd Place with 2 fights 3rd Place points X 1.1
c. 1 <sup>st</sup> place with 3 fights 1 <sup>st</sup> place points X 1.2	c. 2 <sup>nd</sup> place with 3 fights 2 <sup>nd</sup> place points X 1.2	c. 3rd Place with 3 fights 3rd Place points X 1.2
d. 1 <sup>st</sup> place with 4 fights 1 <sup>st</sup> place points X 1.4	d. 2 <sup>nd</sup> place with 4 fights 2 <sup>nd</sup> place points X 1.4	d. 3rd Place with 4 fights 3rd Place points X 1.4
e. 1 <sup>st</sup> place with 5 fights 1 <sup>st</sup> place points X 1.5	e. 2 <sup>nd</sup> place with 5 fights 2 <sup>nd</sup> place points X 1.5	e. 3rd Place with 5 fights 3rd Place points X 1.5
f. 1 <sup>st</sup> place with 6 fights 1 <sup>st</sup> place points X 1.6	f. 2 <sup>nd</sup> place with 6 fights 2 <sup>nd</sup> place points X 1.6	f. 3rd Place with 6 fights 3rd Place points X 1.6
g. 1 <sup>st</sup> place with 7 fights 1 <sup>st</sup> place points X 1.7	g. 2 <sup>nd</sup> place with 7 fights 2 <sup>nd</sup> place points X 1.7	g. 3rd Place with 7 fights 3rd Place points X 1.7
A one-man bracket will receive 1st place and a total of 3 points toward individual ranking.		
If the competitor places in his or her weight division and open weight division, the division with the most points will count toward the ranking and not the sum of the two categories.		

**Article 16 SJJIF National, Professor, and Team Ranking**

- 16.1 SJJIF Ranking is how the SJJIF ranks the top nation, professor, and team in the sport and must follow the following guidelines:
  - a) Competitors are required to identify their nation, team, and professor at registration so that tournament organizers can keep accurate records.
  - b) All Athletes who register giving the same name for nation, team, and professor will contribute to the respective SJJIF ranking.
  - c) No athlete or coach may change the nation, team, or professor they are registered for after the check date has passed or previous event.
- 16.2 The SJJIF World Jiu-Jitsu Championship is the final competition for SJJIF rankings.



- 16.3 **National Ranking** is based on the accumulation of all gold, silver and bronze medals earned by all competitors representing that particular country in all SJJIF sanctioned tournaments during the period of one SJJIF competition year.
- 16.4 **Professor Ranking** is based on the accumulation of all gold, silver and bronze medals earned by all competitors registered under that particular professor in all SJJIF sanctioned tournaments during the period of one SJJIF competition year.
- 16.5 **Team Ranking** is based on the accumulation of all gold, silver, and bronze medals earned by all competitors representing that particular team in all SJJIF sanctioned tournaments during the period of one SJJIF competition year and will be determined by the following guidelines:
- a) Kid Team Points – for all divisions from Kid 1 through Kid 6
  - b) Adult Team Points – for all divisions including Juvenile 16-17, Adult 18, and Master 30 through Master 61
- 16.6 Athletes who place top 3 in a tournament division will accumulate points for their country, professor, and/or team ranking based on of the following point structure:

Tournaments with less than one thousand (<1000) competitors		
7 points for 1 <sup>st</sup> place	3 points for 2 <sup>nd</sup> place	1 point for 3 <sup>rd</sup> Place
Tournaments with over one thousand (>1000) competitors		
14 points for 1 <sup>st</sup> place	6 points for 2 <sup>nd</sup> place	2 points for 3 <sup>rd</sup> Place
The SJJIF Worlds Tournament triples the awarded points		
21 points for 1 <sup>st</sup> place	9 points for 2 <sup>nd</sup> place	3 points for 3 <sup>rd</sup> Place
Points from divisions where only one athlete is signed up will not count toward country ranking, professor ranking, or team ranking.		

- 16.7 If there is a draw in scores, the winner will be decided by the largest number of gold medals received. In the event that there is a continued draw, the winner will be decided by the largest number of silver medals received. In the event that there is a continued draw, the winner will be decided by the largest number of bronze medals received.
- a) In the event that there is a continuous draw the winner will be decided by the medal count of the highest belt.

## Article 17 Code of Conduct

- 17.1 It is the responsibility and obligation of competitors, coaches, officials, administrators, volunteers, and other representatives of the SJJIF to practice and demonstrate the highest principles of sportsmanship and to observe the ethics of competition. Good sportsmanship will be defined as qualities of behavior, which are characterized by courtesy and genuine concern for others. The display of good sportsmanship is a statement of the individual's understanding and commitment to fair play, ethical



behavior, and integrity. Competitors are expected to know and understand the rules of play, be on time, and demonstrate respect to themselves and others.

**17.2 Guidelines for competitors are as follows:**

- a) Treat opponents with respect;
- b) Play hard while competing within the rules;
- c) Exercise self-control at all times;
- d) Set a positive example for others to follow;
- e) Before and after the match, competitors must shake hands and referee's hand;
- f) Respect officials and accepts their decisions without argument or gesture;
- g) Win without boasting and lose without excuses;
- h) No self-scoring or self-cheering during the match;
- i) Athletes should proudly represent their country national team if any, academy team, professor, family, and community;
- j) Athletes must stand at attention throughout the entire national anthem being played for the 1<sup>st</sup> place athlete.
- k) Must not be under the influence of any substance;
- l) Must not remove any part of the uniform when inside the competition area;
- m) Must not jump over the barriers that separate the competition area and the public area;
- n) Must leave the competition area/field of play or enter the space reserved for working officials once matches are completed;
- o) Must not walk barefoot within the competition area or in other areas where it is required to wear shoes.

**17.3 Guidelines for coaches are as follows:**

- a) Treat competitors and opponents with respect;
- b) Inspire competitors with a love for martial arts and a desire to compete fairly;
- c) Be positive role models who others want to follow;
- d) Provide discipline for unsportsmanlike behavior;
- e) Respect the judgment and interpretation of the officials;
- f) Realize teaching extends into the athletic arena;
- g) Maintain temperament and stay behind barricades or on coaching chair while coaching during a match;
- h) Must not be under the influence of any substance.

**17.4 Guidelines for officials are as follows:**

- a) Must have knowledge and understanding of the rules;
- b) Place the welfare of the participants above all other considerations;
- c) Treat competitors and coaches with respect;
- d) Work cooperatively with other officials and other tournament personnel;
- e) Be firm, but fair, in all decisions without regard for previous game incidents;
- f) Maintain confidence, poise, and self-control throughout the tournament;



- g) Never allow outside influences to interfere with competition situations;
- h) Must not be under the influence of any substance.

**17.5 Guidelines for spectators are as follows:**

- a) Attempt to know and understand the rules of competition, and their intent;
- b) Appreciate good play and applaud it, regardless of who performs it;
- c) Cooperate with, and respond enthusiastically with positive cheering;
- d) Show compassion for injured competitors;
- e) Never jeer, heckle, or attempt to distract competitors;
- f) Never use profane or obnoxious language or behavior;
- g) Respect judgment and strategy of coaches, and never criticizes competitors or coaches;
- h) Respect authority of those who administer competition;
- i) Attempt to censure those who behave unruly;
- j) Must not be under the influence of any substance.

**Article 18            Violations and Discipline**

- 18.1 It is the responsibility and obligation of all members and representatives of the SJJIF to practice and demonstrate the highest principles of sportsmanship and to observe the ethics of competition. The display of good sportsmanship is a statement of the individual's understanding and commitment to fair play, ethical behavior, and integrity.
- 18.2 The SJJIF may take disciplinary measures towards its members and participants in SJJIF competitions and/or events for any violation of the SJJIF Statutes & Bylaws, the SJJIF Rulebook, or other SJJIF regulation or bylaw including anti-doping codes, and for participation in activities that are contrary to the SJJIF's Code of Conduct.
- 18.3 The SJJIF Executive Committee has the authority to establish a Disciplinary Committee to evaluate presumed violations in relation to Article 18.2. In the case of a breach or violation, the SJJIF Disciplinary Committee shall be competent and able to take disciplinary action in compliance with the SJJIF Disciplinary Code.
- 18.4 At any SJJIF events, all behavior contrary to the ethics and moral values of sport, and in particular Jiu-Jitsu, and any violation of the SJJIF Code of Conduct may give rise to immediate disciplinary actions taken by the SJJIF.
- 18.5 Any incident giving place to disciplinary action or not, will be communicated immediately to the SJJIF President, SJJIF Executive Committee members, and the SJJIF Disciplinary Committee.
- 18.6 A possible disciplinary decision will be taken after having heard the person or people concerned and any potential witness (es). If the concerned person is a minor, an adult responsible for the minor will accompany them, during the discussion.
- 18.7 As soon as the decision is taken, the Disciplinary Committee is responsible for the following:



- a) Immediately inform the SJJIF President and SJJIF EC about its decision.
  - b) Submit a report of the incident and its decision to the General Secretary within five days of the date of the incident. The report must state the following: facts, including the recall of the alleged facts, a summary of the observations and arguments of the parties, the grounds for the decision, and any other comments.
  - c) The Disciplinary Committee, upon the SJJIF's President's receipt, review, and approval of the documents, will inform the concerned persons about its decision 15 days after the date of the incident.
- 18.8 Disciplinary actions taken by the Disciplinary Committee measure are as follows:
- a) Verbal warning
  - b) Written warning
  - c) Suspension for a period of 1-3 years
  - d) Life ban
- 18.9 If an individual disagrees with a decision, a written appeal may be made to the SJJIF Disciplinary Committee and the General Secretary within one calendar month from the incident date. In the case of suspension, the decision will stand until the outcome of the appeal is heard.
- 18.10 If a situation arises that the SJJIF Statutes & Bylaws, SJJIF Rulebook, or other SJJIF regulation or bylaw does not cover, a decision shall be made by the SJJIF EC.

### **Article 19 Event Operating Rules**

- 19.1 The SJJIF reserves the right to refuse registration or admission to anyone. Any persons who exhibit unsportsmanlike conduct, are disrespectful, engage in unlawful practices, or do not abide requests from SJJIF staff will be ejected from the event and are not entitled to a refund.
- 19.2 Solicitation, sale of products, or promotion of any events are prohibited unless authorized in writing by the SJJIF.
- 19.3 Broadcasts, recordings, or commercial photography are expressly prohibited without written permission from the SJJIF. Personal photography is permitted, but the SJJIF retains the copyright of all photographs taken during an event.

### **Article 20 Registrations**

- 20.1 When an athlete registers for a tournament they are affirming that they meet the requirements put forth in tournament guidelines or those in the SJJIF Rulebook. The following minimum information is required from each competitor to register:
- a) Name
  - b) Age division
  - c) Weight division
  - d) Belt/Skill division
  - e) Instructor
  - f) Nationality
  - g) Academy/Team
  - h) Email address
  - i) Contact phone number
  - j) Emergency contact number



- 20.2 Competitors may register to compete in only one age and belt/skill division for each tournament. For any given belt/skill division a competitor registers for, s/he may not compete at a lower belt/skill division at a later tournament.
- 20.3 There can only be 2 athletes from the same academy in each bracket for competition, in the case that there are more than 2 competitors registered, the tournament organizing committee will attempt to contact the competitor's instructor by email. In the event where the instructor does not get back to the federation within 12 hours, the matchmaker will move the last competitor that registered to a team B. For the Kid division children are matched based on age, belt, and weight. The matchmaker has the right of discretion to move a competitor up or down in weight if determined that the matches are fair for the competitor.
- 20.4 For the Open Weight divisions, a minimum of 3 athletes must sign up with a minimum of 2 athletes from different teams for the respective bracket to be created. There will be a maximum of 4 athletes per team allowed to compete.
- 20.5 Registration for each championship shall adhere to a timetable widely publicized by the SJJIF, and all deadlines will be enforced.

## **Article 21 Qualifications**

- 21.1 An athlete's Professor or Coach is responsible for indicating if the athlete is either physically and/or mentally not qualified or prepared to compete.

## **Article 22 Team Transfers**

- 22.1 If an athlete has recently transferred academies or team, they will be required to wait a 30-day probation period before competing and should not be promoted in rank for a minimum of six (6) months.

## **Article 23 Nationality**

- 23.1 Athletes must be of the same nationality as the National Federation for which they have been entered. Persons appointed by the Executive Committee of the SJJIF shall verify the citizenship of athletes. The evidence of citizenship shall be the production of a birth certificate and/or passport issued by the represented country. In the following cases, particular procedures may be applied:
- a) Where the competitions are being held in a country in which the residents do not uphold passports while in that country.
  - b) Where there is a possible problem of "joint citizenship", e.g. For Puerto Rico an acceptable substitute for the passport will be a letter or certificate from the athlete's National Olympic Committee or, if there is no such body, from the National Sports Authority confirming the athlete's residence in that country and citizenship.
- 23.2 If a competitor has multiple citizenships they may compete for only one country. A competitor who has represented one country in the World Championship, or in tournaments organized by the SJJIF, and who has changed their nationality or acquired a



new nationality may participate to represent their new country provided that at least three (3) years have passed since the athlete last represented their former country.

- 23.3 If the two National Federations concerned agree, they may request to shorten the period of three years or even to cancel the duration. The SJJIF will not autonomously shorten the three (3) years period without written agreement from both of the national federations concerned.
- 23.4 The request to shorten or cancel the period of three years shall be sent by the host National Federation to the SJJIF General Secretary. This request has to be sent with the documents below:
- a) Letter from the athlete, who has already represented their country, requesting permission to represent their new federation.
  - b) Letter from the president of the national federation (the country of origin) confirming the change of nationality of the concerned athlete.
  - c) Letter from the president of the national federation (the host country) authorizing the athlete to represent the new federation in international competitions.
  - d) A copy of the athlete's passport mentioning the nationality of the host country.
- 23.5 On receipt of a complete request, the SJJIF General Secretary will examine request and forward to the SJJIF Executive Committee for approval. If the majority of the SJJIF Executive Committee approves the request, the SJJIF General Secretary will confirm the acceptance of the application to the concerned parties, with both origin and host federations in copy. Any athlete disrespecting this rule may be subject to disciplinary measures.

#### **Article 24 Gender Control**

- 24.1 Gender control is the responsibility of the SJJIF National Federations. The SJJIF refers to the International Olympic Committee recommendation currently in force, and if any, the one modified by the International Olympic Committee over time. All decisions of a Member Federation for an athlete's gender must be communicated with the briefest delay to the SJJIF President.
- 24.2 Any official complaint of an SJJIF National Federation, a Continental Federation, or a member of the SJJIF Executive Committee concerning an athlete's gender must be duly motivated and must be sent to the SJJIF President. The SJJIF Executive Committee and/or Medical Committee will decide if it is necessary to deliberate and to make a decision on this topic. The SJJIF Executive Committee can also refer to the National Federation of the athlete concerned so that they decide on the gender of the athlete concerned.
- 24.3 Contestations of the National Federation's decision regarding an athlete's gender must be submitted exclusively by the athlete concerned to the SJJIF General Secretary.
- 24.4 The SJJIF Executive Committee and/or Medical Committee will have the full authority to ask all of the concerned persons for any documents or information necessary for the hearing of the case. An internal regulation will be established in order to guarantee the



confidentiality of the procedure as well as the respect of the applicable provisions concerning protection of data and private life.

## **Article 25 Sports Integrity**

25.1 The integrity of the sport depends on the outcome of sporting events and competitions being based entirely on the merits of the participants involved. Any form of corruption that might undermine public confidence in the integrity of a Jiu-Jitsu competition is fundamentally contrary to the spirit of sport and subject to severe disciplinary action.

## **Article 26 Matchmaking**

- 26.1 If a match takes place and seems to have been played to a pre-determined result, violating the SJJIF rules, further investigation may be undertaken and any findings of matching will result in disciplinary action.
- 26.2 If in SJJIF events, two athletes from the same team, nation or two athletes not from the same nation, are opposed and one athlete is injured or ill and has to withdraw they must have a medical certificate from the SJJIF Medical Director.
- 26.3 The result of the contest will be cancelled if any athlete is caught not telling the truth.
- 26.4 The SJJIF may undertake further investigation and any findings of match fixing will result in disciplinary action.

## **Article 27 Brackets**

- 27.1 All SJJIF tournaments are run on a single-elimination tournament bracket system.
- 27.2 Divisions are separated and classified by age, rank and weight as per Article 28.4, 29.4, 30.4, 31.5, 34.6, 34.7 and 34.9. For each division there will be a separate bracket.
- 27.3 For each tournament, brackets will be created prior to the beginning of the tournament. Brackets will not be changed the day of the tournament.
- 27.4 Competitors will be divided by age, skill level group or belt, rank, and gender. Those divisions will then be further divided into divisions based on weight relative to others competing in that age, gender, and belt divisions for that day's competition. The weight divisions identified in the SJJIF Rulebook Article 34.1-34.9 will serve as a guide for dividing divisions. The Event Director and the Matchmaker will have the option to combine weight divisions in order to ensure competition.
- 27.5 National Federations and/or Continental Federations with insufficient number of participants per belt and/or weight divisions have the right to combine weight and/or belt divisions to ensure competition. These events will be considered Special Events and the following guidelines apply to these circumstances:
- a) Matchmakers must prioritize the fair play of the competition and consider the preservation of health and longevity of the athlete.
  - b) Combined divisions will not be considered a specific belt division match, rather, a match up division.



- c) Combined divisions must abide by the competition rules and time of the youngest and/or lower belt level competitor.
- 27.6 All athletes, even in a 1-man bracket, must undergo the weigh-in and uniform inspection and be approved to compete in order to receive a medal and/or participate in the Open Weight divisions.
- 27.7 For every competition round prior to the semi-finals, defeated competitors are eliminated from competition. Competitors defeated in the semi-finals of a bracket will be advanced into a match for third place.
- 27.8 In the case of a bracket with three competitors, the loser of the first match will compete with the third opponent. The winner of that match will compete with the winner of the initial match.
- 27.9 Athletes will be given rest periods between their matches equal to or no less than the designated duration of their division's matches. For the final match athletes will be given a rest period that is double the match time for respective divisions.
- 27.10 The following section explains and assists in understanding the bracket system.
  - a) **Open bracket** – When a bracket consists of 5, 6, 7 competitors and they are given a bye. The reason for the bye in the first match is to avoid a bye in the semifinals or finals.
  - b) **Closed bracket** – When a bracket consists of 2, 4, 8, 16 competitors, in these brackets there are no byes.
  - c) **Bye** - The practice of allowing a competitor to advance to the next round of the bracket without competing due to the number of competitors in that specific bracket. In cases where the number of competitors at the start of the tournament is not a power of two, some competitors may receive a bye in the first round/match, which entitles these competitors to advance in their bracket to the second round automatically without competing. The bye is given in the first match so that there are no byes in the semifinals or finals.
  - d) Competitors of the same team will be placed on opposite ends of the bracket so that if they meet, it will only be at the finals. In the case that the only competitors in the bracket are from the same team, they must compete in order to determine a winner and be awarded points.

27.11 **2 Man Bracket** - Winner of the match is awarded gold.

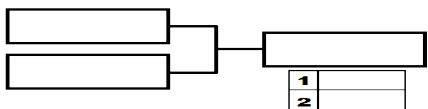

27.12 **3 Man Bracket** - Winner of the first match goes through to the final and the losing competitor faces the third competitor in the bracket. The competitor that wins the second match, regardless of whether it is the same athlete to lose the first match goes through to the final to face the winner of the first match. If there are two competitors from the same team in the bracket and one loses, the other competitor from the same team



will advance to the final. If an opponent does not show-up or is disqualified, the remaining competitors will compete once and the winner of the match will win gold.

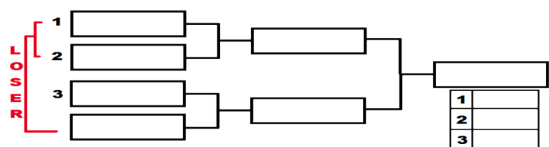

27.13 **4 Man Bracket** - Winners of the first match will move on to the finals, the losing competitors will then compete for third place. If an opponent does not show-up or is disqualified, the bracket will continue as a 4-man bracket.

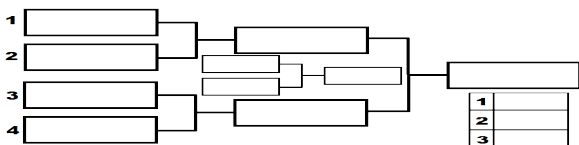

27.14 **5 Man Bracket** – Three (3) athletes will be given byes to the semifinals while two (2) athletes will have to compete to move forward to the semi-finals.

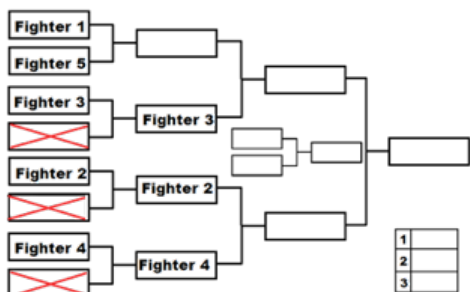

27.15 **6 Man Bracket** - Two (2) athletes will be given byes to the next round, winners of matches move on to the next round, and losers of the first round are eliminated. Once in semifinals, winners move forward to finals, and the losers of that match compete for third place.

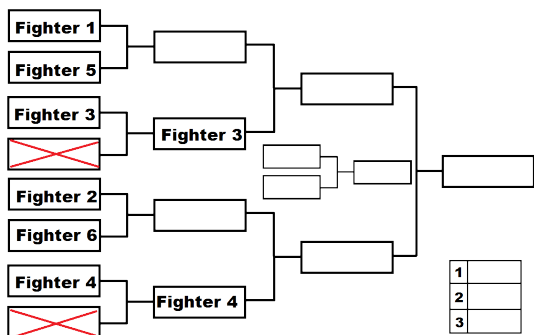

27.16 **8 Man Bracket**—Winners of initial fights continue to the semifinals, losing competitors are eliminated, winners of the semifinals move to the finals to be placed in first or second place, as the losing competitors compete for third place.



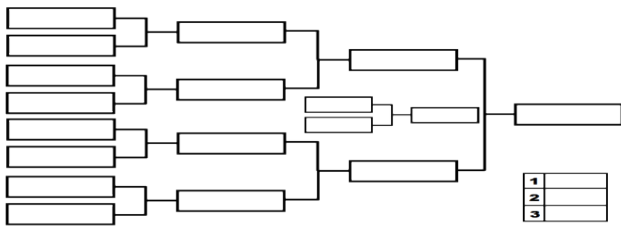

27.17 **16 Man Bracket**—Winners of each round move forward only, the losing opponent is automatically eliminated until the semifinals are reached, winners of the semifinals move on to finals, and the losing opponents compete for third place.

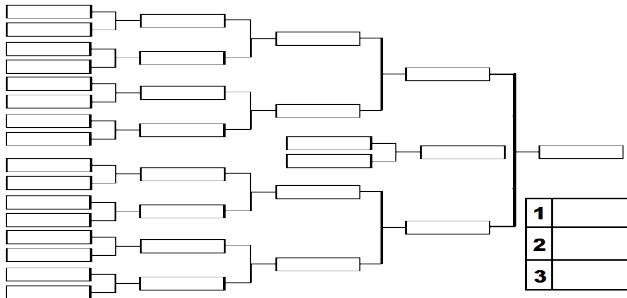

27.18 During competition, athletes will be identified by the following guidelines:

- a) The competitor on the top of a bracket match will be identified as Competitor 1 and will wear the green and yellow belt during GI competition or the green and yellow ankle band during No GI competition regardless of uniform color.
- b) The competitor on the bottom of a bracket match will be identified as Competitor 2 and will wear no additional belt or ankle band during competition.
- c) Competitor 1, wearing the green and yellow belt or ankle band, will be identified by the green background on the scoreboard. Competitor 2 will be identified by the white background on the scoreboard.



## Article 28 Age Divisions

28.1 Competitors will be grouped in age divisions by year of birth, and not their actual age.

28.2 The SJJIF will not place children of the opposite sex, who are over the age of 12, in the same division.



28.3 The SJJIF recognizes men and women competitions. Matches between men and women are not permitted.

28.4 The SJJIF recognizes the following age divisions:













Code	Division Name	Division Age Range	Division Belt Rank
KD1	Kid 1	Turning 4 or 5 in the year the tournament is held	WHT, GRY
KD2	Kid 2	Turning 6 or 7 in the year the tournament is held	WHT, GRY, YLW
KD3	Kid 3	Turning 8 or 9 in the year the tournament is held	WHT, GRY, YLW
KD4	Kid 4	Turning 10 or 11 in the year the tournament is held	WHT, GRY, YLW, ORA
KD5	Kid 5	Turning 12 or 13 in the year the tournament is held	WHT, GRY, YLW, ORA, GRN
KD6	Kid 6	Turning 14 or 15 in the year the tournament is held	WHT, GRY, YLW, ORA, GRN
JV16-17	Juvenile 16-17	Turning 16 or 17 in the year the tournament is held	WHT, BLU, PRP
AD18	Adult 18	Turning 18 or older in the year the tournament is held	WHT, BLU, PRP, BRW, BLK
MT30	Master 30	Turning 30 or older in the year the tournament is held	WHT, BLU, PRP, BRW, BLK
MT36	Master 36	Turning 36 or older in the year the tournament is held	WHT, BLU, PRP, BRW, BLK
MT41	Master 41	Turning 41 or older in the year the tournament is held	WHT, BLU, PRP, BRW, BLK
MT46	Master 46	Turning 46 or older in the year the tournament is held	WHT, BLU, PRP, BRW, BLK
MT51	Master 51	Turning 51 or older in the year the tournament is held	WHT, BLU, PRP, BRW, BLK
MT56	Master 56	Turning 56 or older in the year the tournament is held	WHT, BLU, PRP, BRW, BLK
MT61	Master 61	Turning 61 or older in the year the tournament is held	WHT, BLU, PRP, BRW, BLK

## Article 29 Kid Belt System (15 years of age and younger)

- 29.1 The minimum age requirement is based and counted from the year the athlete was born (i.e.; if an athlete was born in 2000, her age is considered 10 for all of 2010).
- 29.2 Instructors decide how long it takes for a student to be promoted, as long as the minimum times required for each belt are fulfilled. However, a child competitor will not be authorized to compete for a 3<sup>rd</sup> time at the same belt level if the child competitor has been the champion of the same tournament for 2 years in a row in a given belt.
- 29.3 During No GI competitions divisions might be divided by the belt system or by skill levels, depending on the tournament.
- 29.4 For competitions, belts of the same color will be joined in groups as follows:
- Grey belt group - white/grey, solid grey, and grey/black are grouped together







- b) Yellow belt group - white/yellow, solid yellow, and yellow/black are grouped together
  - c) Orange belt group - white/orange, solid orange, and orange/black are grouped together
  - d) Green belt group - white/green, solid green, and green/black are grouped together
- 29.5 During a GI competition, one competitor will use a competition belt for the purpose of distinguishing between competitors. It is not a promotion or grade belt.
- 29.6 During a No GI competition, one competitor will use a green and yellow ankle band for the purpose of distinguishing between competitors.
- 29.7 Children may be promoted through belts in the following order: white, grey/white, solid grey, grey/black, yellow/white, solid yellow, yellow/black, orange/white, solid orange, orange/black, green/white, solid green, and green/black. Each belt has 5 levels, a clear belt and then 4 stripes that may be awarded for time, knowledge, behavior, and tournament performance. Only black belts certified by the SJJIF may promote students through the belts listed.

Skill Level Group	Kid Belt Group	Belt	Belt Sample	Age Group	Minimum time in Grade
Beginner	White belt group	White		Any	Beginner
Intermediate	Gray belt group	Gray/White		4-15	8 months in previous belt
		Solid Gray		5-15	8 months in previous belt
		Gray/Black		6-15	8 months in previous belt
Intermediate	Yellow belt group	Yellow/White		7-15	8 months in previous belt
		Solid Yellow		8-15	8 months in previous belt
		Yellow/Black		9-15	8 months in previous belt
Advanced	Orange belt group	Orange/White		10-15	8 months in previous belt
		Solid Orange		11-15	8 months in previous belt
		Orange/Black		12-15	8 months in previous belt
Advanced	Green belt group	Green/White		13-15	8 months in previous belt
		Solid Green		14-15	8 months in previous belt
		Green/Black		15-15	8 months in previous belt



**Article 30 Juvenile & Adult Belt System (16 years of age and older)**

- 30.1 The minimum age requirement is based and counted from the year the athlete was born (i.e.; if an athlete was born in 2000, her age is considered 10 for all of 2010).
- 30.2 Instructors decide how long it takes for a student to be promoted, as long as the minimum times required for each belt are fulfilled. However, a competitor will not be authorized to compete for a 3<sup>rd</sup> time at the same belt level if the competitor has been the champion of the same tournament for 2 years in a row in a given belt, with the exception of black belts.
- 30.3 During No GI competitions divisions might be divided by the belt system or by skill levels, depending on the tournament.
- 30.4 Adults may be promoted through belts in the following order: white, blue, purple, brown, and black. Each belt has 5 levels, a clear belt and then 4 stripes that may be awarded for time, knowledge, behavior, and tournament performance.

Skill Level Group	Adult Belt	Belt Sample	Age Group	Minimum time in Grade
Beginner	White Belt		Any	Beginner
Intermediate	Blue Belt		16 & up	1 year in previous belt
Intermediate	Purple Belt		17 & up	1 ½ years in previous belt
Advanced	Brown Belt		18 & up	1 year in previous belt
Advanced	Black Belt		19 & up	1 year in previous belt

- 30.5 The SJJIF recognizes the following additional guidelines to the juvenile and adult belt system:
  - a) Any grey, yellow, orange, or green belt automatically becomes a blue belt at the year of turning 16 years of age.
  - b) In order to be graded a purple belt at 16 years of age it is required that the athlete has spent at least 2 years as a green belt.
  - c) In order to be graded a purple belt at 17 years of age, it is required that the athlete has spent at least 1 year as a green belt and 1 year as a blue belt.
  - d) In the case where an athlete was graded from green belt straight to purple belt, then the minimum time required before he can be awarded the brown belt is 2 years
- 30.6 The following is the criteria for which instructors may promote students:
  - a) A black belt may promote students from white belt to purple belt.
  - b) A 1<sup>st</sup> degree black belt may promote students from white belt to brown belt.
  - c) A 2<sup>nd</sup> degree or higher black belt may promote students from white belt to black belt.
- 30.7 During a GI competition, one competitor will use a competition belt for the purpose of distinguishing between competitors. It is not a promotion or grade belt.

**COMPETITION BELT ONLY**



30.8 During a No GI competition, one competitor will use a green and yellow ankle bank for the purpose of distinguishing between competitors.



**Article 31 Black Belt System**

- 31.1 Only athletes 19 years of age or older may be awarded a black belt.
- 31.2 In order to request a black belt certificate, it is necessary to be currently affiliated with the SJJIF.
- 31.3 In order to be awarded degrees as a black belt, it is necessary that the black belt be a current SJJIF member and listed as a main instructor or assistant instructor at an SJJIF member school.
- 31.4 In order to be awarded grandmaster belts, it is necessary that the black belt be a current SJJIF member and listed as a main instructor or assistant instructor at an SJJIF member school.
- 31.5 Black belts have seven levels, a black belt plus 6 degrees that can only be awarded by the SJJIF according to the following guidelines:

Skill Level Group	Black Belt Title	Black Belt Group	Black Belt Sample	Age Group	Minimum time in Grade
Advanced	Black Belt	Black Belt		19 & up	1 year in previous belt
Advanced	Black Belt	1 <sup>st</sup> Degree Black Belt		22 & up	3 years in previous belt
Advanced	Black Belt	2 <sup>nd</sup> Degree Black Belt		25 & up	3 years in previous belt
Advanced	Professor	3 <sup>rd</sup> Degree Black Belt		28 & up	3 years in previous belt
Advanced	Professor	4 <sup>th</sup> Degree Black Belt		33 & up	5 years in previous belt
Advanced	Professor	5 <sup>th</sup> Degree Black Belt		38 & up	5 years in previous belt
Advanced	Professor	6 <sup>th</sup> Degree Black Belt		43 & up	5 years in previous belt



Advanced	Master	7 <sup>th</sup> Degree Red & Black Belt		50 & up	7 years in previous belt
Advanced	Master	8 <sup>th</sup> Degree Red & Black Belt		57 & up	7 years in previous belt
Advanced	Grand Master	9 <sup>th</sup> Degree Black Belt		67 & up	10 years in previous belt
Advanced	Grand Master	10 <sup>th</sup> Degree Black Belt		82 & up	15 years in previous belt

## Article 32 Belt Integrity

- 32.1 Belt integrity refers to the accuracy in which an athlete's belt reflects their skills and knowledge of the art. The SJJIF believes in the importance of all practitioners following the above minimum time in a grade prior to promotion and verifies all members' belt promotions with their professor in an effort to preserve belt integrity and lineage.
- 32.2 The SJJIF has implemented Belt Integrity rules to avoid the practice of professors not promoting athletes to the next rank or when an athlete competes at a skill-bracket deemed less rigorous than their actual level of competitive ability, commonly referred to as "sandbagging".
- 32.3 The SJJIF will have no tolerance for "sandbagging" at any sanctioned event. Every competitor is subject to the SJJIF investigating their belt with academies and coaches or examining past official and unofficial tournament results.
- 32.4 The SJJIF will not allow an athlete who has proven to be a Judo or Ju Jitsu Black Belt and/or has experience in wrestling competing at the college level, national level, Olympic wrestling level, or in Greco-Roman, Sambo, or that has fought MMA professionally to compete in any competition as a white belt.
- 32.5 Athletes who do not meet the requirements put forth in championship guidelines or those in the SJJIF Rulebook may be disqualified at any moment prior to, during, or following the competition.
- 32.6 The athlete may only compete as the belt they are registered with under the SJJIF (or its affiliates). If the athlete is promoted before the minimum age or the minimum time requirement of the previous belt is met, he/she cannot compete in the current belt or the previous one.
- 32.7 Once an athlete's gradation occurs, the athlete cannot compete in the previous belt anymore. If an athlete gets promoted during a competition after the division is done, the athlete will be unable to compete in the open weight division.
- 32.8 A competitor cannot compete in an SJJIF event for a 3<sup>rd</sup> time once he or she has placed in 1<sup>st</sup> place twice for the same event, in same belt rank, except for black belts.
- 32.9 If a white belt has over one year practicing BJJ and meets any of the below criteria he/she can no longer compete in the white belt division:
- has placed 1st place in a SJJIF world event
  - has placed 1st place in two SJJIF continental event



- c) has placed 1st place in 5 events.
- d) has placed 1st in the year ranking.

32.10 Changes may be made to an athlete's registration up to the date when registration closes for a tournament.

32.11 If an athlete has recently changed academies or team, he/she should not be promoted in rank for a minimum of six (6) months.

### Article 33 Match Times

33.1 In all competitions athletes will be given rest periods between their matches equal to or no less than the designated duration of their division's matches. Except for the final match which is double the match time for respective divisions.

#### 33.2 Time Limits for Tournaments in the GI & No GI (match length in minutes)

	Kid 1	Kid 2	Kid 3	Kid 4	Kid 5	Kid 6
Minutes	2	2	3	4	4	4

		Juvenile	Adult	Master 30	Master 36 and up
Beginner	White	5	5	5	5
Intermediate	Blue	5	6	5	5
	Purple	5	7	6	5
Advanced	Brown	X	8	6	5
	Black	X	8	6	5

### Article 34 Weight Divisions

34.1 The SJJIF utilizes weight divisions to help minimize injuries and remove weight advantages.

34.2 Competitors, or parents of children competitors, are responsible for ensuring that the weight is met with GI and/or rash guard already on. Any athlete that is over their registered weight is subject to disqualification.

34.3 As far as weight reduction for competition is concerned, the SJJIF strongly discourages the practice of dehydration or excessive caloric restriction; the use of diuretics, laxatives, and self-induced vomiting.

34.4 The SJJIF strongly recommends that children compete at their natural weight and do not support or encourage any form of weight cutting for competition.

34.5 Weigh-in guidelines for competitors is as follows:

- a) All Athletes must clear weight prior to their first match.
- b) Athletes must have their uniform for competition on for weigh in.
- c) Athletes are allowed to weigh in without knee or elbow braces, but they will have to be wearing them at the time of the uniform inspection.



- d) The athlete cannot step on the scale with shoes or any item besides his/her regular uniform and equipment permitted for use during matches.
- e) Each athlete shall only mount the official scale of the event to have his/her weight taken once unless authorized.

34.6 Kid weight divisions for GI and No GI competitions are as follows:

WEIGHT/PESO	KID 1		KID 2		KID 3		KID 4		KID 5		KID 6	
	GI	No GI	GI	No GI	GI	No GI	GI	No GI	GI	No GI	GI	No GI
ROOSTER	39 lbs	36 lbs	45 lbs	42 lbs	50 lbs	47 lbs	60 lbs	57 lbs	70 lbs	67 lbs	100 lbs	97 lbs
GALO	17.7 kg	16.3 kg	20.4 kg	19.1 kg	22.7 kg	21.3 kg	27.2 kg	25.9 kg	31.8 kg	30.4 kg	45.4 kg	44 kg
SUPER FEATHER	44 lbs	41 lbs	50 lbs	47 lbs	60 lbs	57 lbs	70 lbs	67 lbs	83 lbs	80 lbs	113 lbs	110 lbs
PLUMA	20 kg	18.6 kg	22.7 kg	21.3 kg	27.2 kg	25.9 kg	31.8 kg	30.4 kg	37.6 kg	36.3 kg	51.3 kg	49.9 kg
FEATHER	49 lbs	46 lbs	60 lbs	57 lbs	70 lbs	67 lbs	80 lbs	77 lbs	97 lbs	94 lbs	126 lbs	123 lbs
PENA	22.2 kg	20.9 kg	27.2 kg	25.9 kg	31.8 kg	30.4 kg	36.3 kg	34.9 kg	44 kg	42.6 kg	57.2 kg	55.8 kg
LIGHT	54 lbs	51 lbs	70 lbs	67 lbs	80 lbs	77 lbs	90 lbs	87 lbs	111 lbs	108 lbs	139 lbs	136 lbs
LEVE	24.5 kg	23.1 kg	31.8 kg	30.4 kg	36.3 kg	34.9 kg	40.8 kg	39.5 kg	50.3 kg	49 kg	63 kg	61.7 kg
MIDDLE	59 lbs	56 lbs	80 lbs	77 lbs	90 lbs	87 lbs	100 lbs	97 lbs	125 lbs	122 lbs	152 lbs	149 lbs
MEDIO	26.8 kg	25.4 kg	36.3 kg	34.9 kg	40.8 kg	39.5 kg	45.4 kg	44 kg	56.7 kg	55.3 kg	68.9 kg	67.6 kg
MEDIUM HEAVY	Over 59 lbs	Over 56 lbs	Over 80 lbs	Over 77 lbs	100 lbs	97 lbs	110 lbs	107 lbs	139 lbs	136 lbs	165 lbs	162 lbs
MEIO-PESADO	Acima de 26.8 kg	Acima de 25.4 kg	Acima de 36.3 kg	Acima de 34.9 kg	45.4 kg	44 kg	49.9 kg	48.5 kg	63 kg	61.7 kg	74.8 kg	73.5 kg
HEAVY					110 lbs	107 lbs	120 lbs	117 lbs	153 lbs	150 lbs	178 lbs	175 lbs
PESADO					49.9 kg	48.5 kg	54.4 kg	53.1 kg	69.4 kg	68 kg	80.7 kg	79.4 kg
SUPER HEAVY					Over 110 lbs	Over 107 lbs	130 lbs	127 lbs	165 lbs	162 lbs	191 lbs	188 lbs
SUPER PESADO					Acima de 49.9 kg	Acima de 48.5 kg	59 kg	57.6 kg	74.8 kg	73.5 kg	86.6 kg	85.3 kg
ULTRA HEAVY							Over 130 lbs	Over 127 lbs	Over 165 lbs	Over 162 lbs	Over 191 lbs	Over 188 lbs
PESADISSIMO							Acima de 59 kg	Acima de 57.6 kg	Acima de 74.8 kg	Acima de 73.5 kg	Acima de 86.6 kg	Acima de 85.3 kg
OPEN	NO OPEN WEIGHT CATEGORY											



34.7 Juvenile, Adult, and Master weights divisions for Men and Women in GI and No GI competitions are as follows:

WEIGHT/PE SO	MALE JUVENILE		MALE ADULT & MASTER		FEMALE ADULT & MASTER		JUVENILE FEMALE	
	JUVENIL MASCULINO		MASCULINO ADULTO E MASTER		FEMININO ADULTO E MASTER		JUVENIL FEMININO	
	GI	No GI	GI	No GI	GI	No GI	GI	No GI
ROOSTER			127.5 lbs	123.5 lbs	107 lbs	103 lbs	105 lbs	101 lbs
GALO			57.6kg	56 kg	48.5 kg	46.7 kg	47.6 kg	45.8 kg
SUPER FEATHER	120 lbs	116 lbs	141 lbs	137 lbs	120 lbs	116 lbs	115 lbs	111 lbs
PLUMA	54.4 kg	52.6 kg	64 kg	62.1 kg	54.4 kg	52.6 kg	52.2 kg	50.3 kg
FEATHER	135 lbs	131 lbs	154 lbs	150 lbs	135 lbs	131 lbs	130 lbs	126 lbs
PENA	61.2 kg	59.4 kg	70 kg	68 kg	61.2 kg	59.4 kg	59 kg	57.2 kg
LIGHT	150 lbs	146 lbs	167.5 lbs	163.5 lbs	150 lbs	146 lbs	145 lbs	141 lbs
LEVE	68 kg	66.2 kg	76 kg	74.2 kg	68 kg	66.2 kg	65.8 kg	64 kg
MIDDLE	165 lbs	161 lbs	181 lbs	177 lbs	165 lbs	161 lbs	160 lbs	156 lbs
MEDIO	74.8 kg	73 kg	82.1 kg	80.3 kg	74.8 kg	73 kg	72.6 kg	70.8 kg
MEDIUM HEAVY	180 lbs	176 lbs	194.5 lbs	190.5 lbs	180 lbs	177 lbs	Over 160 lbs	Over 156 lbs
MEIO- PESADO	81.6 kg	79.8 kg	88.2 kg	86.2 kg	81.6 kg	80.3 kg	Acima de 72.6 kg	Acima de 70.8 kg
HEAVY	195 lbs	191 lbs	207.5 lbs	203.5 lbs	Over 180 lbs	Over 177 lbs		
PESADO	88.5 kg	86.6 kg	94.1 kg	92.3 kg	Acima de 81.6 kg	Acima de 80.3 kg		
SUPER HEAVY	Over 195 lbs	Over 191 lbs	221 lbs	217 lbs				
SUPER PESADO	Acima de 88.5 kg	Acima de 86.6 kg	100.2 kg	98.4 kg				
ULTRA HEAVY			Over 221 lbs	Over 217 lbs				
PESADISSI MO			Acima de 100.2 kg	Acima de 98.4 kg				
OPEN	FREE/LIVRE							



- 34.8 Open divisions where weight classes are not defined are also available at tournaments for all belts, from Juvenile division and above.
- 34.9 **Adult Weight Divisions for Adapted Jiu-Jitsu and Special Events for Men and Women in GI and No GI competitions are as follows:**

WEIGHT/PESO	MALE ADULT		FEMALE ADULT	
	MASCULINO ADULTO		FEMININO ADULTO	
	GI	No GI	GI	No GI
ROOSTER	127.5 lbs	123.5 lbs	107 lbs	103 lbs
	57.8 kg	56 kg	48.5 kg	46.7 kg
FEATHER +	154 lbs	150 lbs	135 lbs	131 lbs
	69.9 kg	68 kg	61.2 kg	59.4 kg
LIGHT MIDDLE	181 lbs	177 lbs	165 lbs	161 lbs
	82.1 kg	80.3 kg	74.8 kg	73 kg
LIGHT HEAVY	207.5 lbs	203.5 lbs	Over 180 lbs	Over 161 lbs
	94.1 kg	92.3 kg	Acima de 81.6 kg	Acima de 73 kg
HEAVY +	Over 207 lbs	Over 203.5 lbs		
	Acima de 94.1 kg	Acima de 92.3 kg		

### Article 35 Uniform Requirements

- 35.1 The SJJIF utilizes uniform requirement to help make competition fair and safe for all athletes.
- 35.2 If a competitor does not meet any of the standards for equipment or uniform, he/she will be given 5 minutes to change. If the competitor cannot meet the equipment and uniform standards within those 5 minutes, they will be disqualified.
- 35.3 The competitor must wear under garments under their shorts or pants, due to the risk that the suit might become torn or undone. In the case that pants are torn, the competitor will be given 5 minutes to find another pair of pants to wear. If the competitor cannot change within 5 minutes, he/she will be immediately disqualified.



- 35.4 When the competitor has any part of the uniform ripped during the competition, the referee will allow 5 minutes for that competitor to get changed. The competitor must be cleared by the uniform inspector prior to returning to the mat area. If the competitor cannot change within 5 minutes, he/she will be immediately disqualified.
- 35.5 Competitors must compete in the uniform they wore when they weighed in. Should the competitor weigh in with one uniform and then change into another before their first competition or between their competitions, he/she will be disqualified.
- 35.6 Wrestling shoes, or any shoes, socks, cups and headgear will not be permitted. Any brace or piece of protective equipment that may alter the outcome of the match may not be worn. This includes, but is not limited to, braces with metal parts and supports that provide extra grip against the mat.
- 35.7 Uniforms, both in GI and No GI, may not have patches and/or text in any form that contain phrases, symbols, or slogans that are offensive to gender, culture, race, sexual orientation, religion, and/or political ideologies or that promote violence, sexual acts, drugs, alcohol and/or tobacco.
- 35.8 It is required that all competitors wear shoes, sandals, or slippers when off the competition area to avoid feet injury and/or germs on the mat area.
- 35.9 In order to standardize uniforms in competition, general guidelines are as follows:
- All male competitors are allowed to wear rash guards only underneath the GI.
  - All female competitors are not allowed to wear t-shirts, tank tops or any cotton material undergarment and are required to wear rash guards, sports bras, or an equivalent lycra garment underneath their GI. Female under garments should not be sexually explicit or provocative.
- 35.10 Female athletes are permitted to cover their heads. The Head Cover requirements are as follows:
- Must be fixed and made with elastic fabric (or have elastics at the borders);
  - Be made without any kind of plastic or hard materials;
  - Be made with no strings of any kind;
  - Be clear of any inscription or logo;
  - Must be completely in black color;
  - The head covering can be made of elastic material, must be fully black in color and can cover the neck, ears and hair, like a wetsuit headpiece. The face must remain fully visible.
- 35.11 Uniform regulations for GI competition are as follows:
- GIs are to be constructed of cotton or similar material and in good condition. The material may not be excessively thick or stiff to the point where it hinders the



opponent from executing a submission. The GI top must be made of single weave, gold weave, double weave or a similar weight material.

b) Colors may be black, white or royal blue. No combined colors will be allowed (e.g.



white GI with blue pants or a white GI with black lapels).

- c) The jacket and the trousers should be of a uniform color and correspond to the following color references:
  - i. White: Snow white reference.
  - ii. Blue: maximum Pantone color: 285M 5M minimum Pantone color: 286M.
  - iii. Black: maximum Pantone color: 050505M minimum Pantone color: 2 323233M.

- d) The jacket is to be of sufficient length, down to the pelvis.
- e) The sleeves must reach a point no more than 5cm back from the wrist when the arms are extended in front of the body.
- f) When the arms are held out to the sides, level to the shoulders, the material of the sleeves must have at least 7cm of slack along the length of the arm.
- g) The lapel of the jacket must be 4-5cm wide and less than 1.3cm thick.
- h) A belt with width of 4-5cm and color corresponding to rank tied around the waist with a double knot, tight enough to secure the GI closed. The belt must have the degree bar.
- i) The pants are to be tied securely at the waist above the buttocks. If they are grabbed and pulled down, they should remain affixed where they

Belt width between 4 and 5 cm (1.5 to 2inch)  
 Belt tip between 20 and 30cm (8to 12inch)  
 Belt must have the degree bar

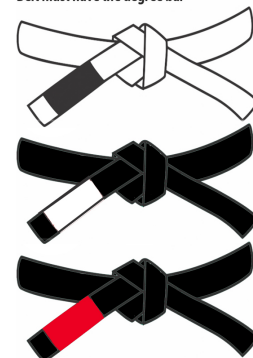

are secured at the waist. They must be of appropriate length, reaching a point no more than 8cm up from the ankle.

- j) When the athlete is standing, the material of the pants must have at least 5cm of slack along the length of the leg.
- k) Athletes are not permitted to compete with any part of the uniform torn.

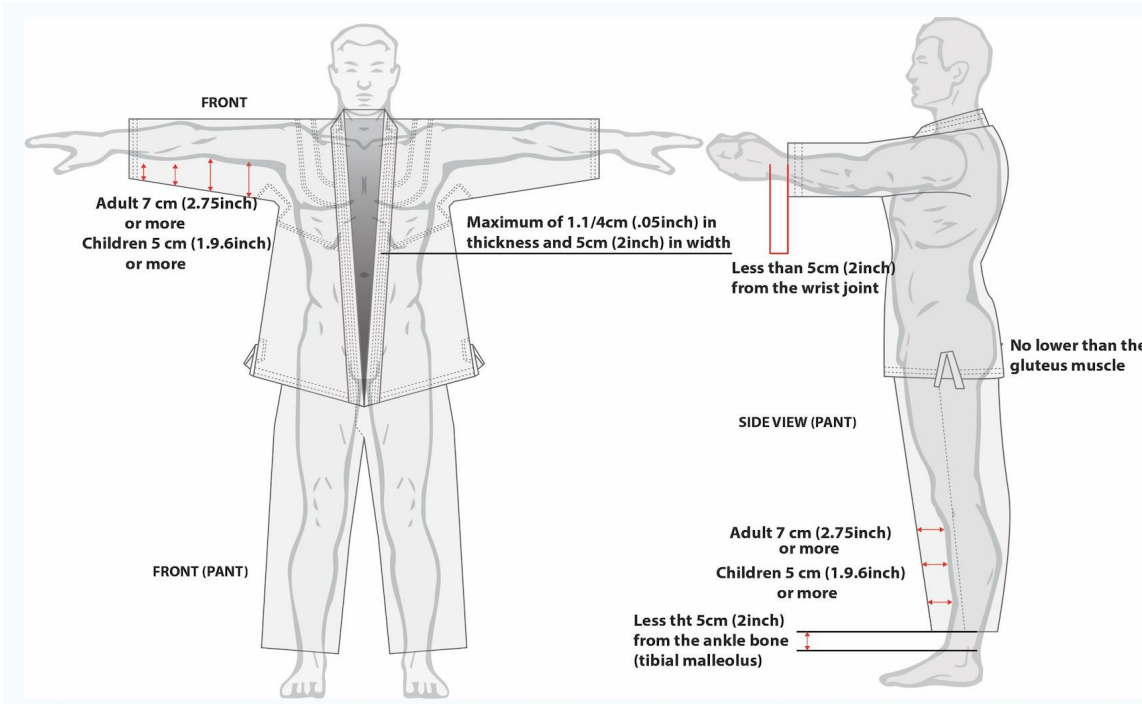

35.12 Patches and embroidery may be securely affixed only in prescribed areas on the GI that do not impede regular gripping of the GI. Any patches with unfixed edges or tears must be removed. Patch Regulations for the GI are as follows:

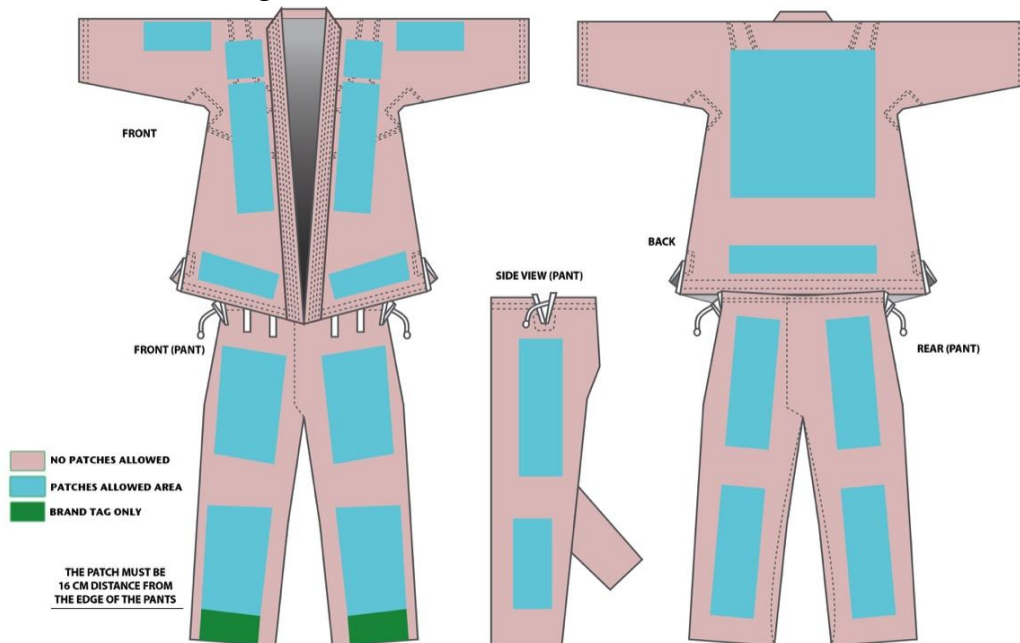

35.13 Uniform regulations for No GI competition are as follows:

- a) Rash guards must be fitted and hug the body with a round collar (V-necks are not allowed).
- b) Rash guards may have short or long sleeves but cannot be without sleeves.
- c) Additional uniform regulations for Juvenile, Adult, and Master divisions during No GI competition for SJJIF World Jiu-Jitsu Championship are as follows:
  - i. The rash guard must be white or black with at least 10% of the color of the athlete's belt rank. Rash guards that are 100% the color of the belt rank of the athlete are also acceptable.



- d) The shorts can be of any color, they must be free of zippers and pockets.
- e) The shorts must be proper secured to avoid exposure.
- f) Shorts may be a loose board-like short or tight like vale-tudo shorts as long as they are at least mid-thigh length.
- g) Lycra pants may pass the knee, but not the ankle, and cannot be a loose fit.
- h) Athletes may choose to compete in shorts or lycra pants, or both.
- i) The shorts are to be tied securely at the waist, above the buttocks. If they are grabbed and pulled down, they should remain affixed where they are secured at the waist.
- j) Athletes are not permitted to compete with torn shorts or torn rash guards.
- k) Patches and embroidery may be securely affixed in any place on the shorts or rash guard. Any patches with unfixed edges or tears must be removed.



### LEGAL NOGI COMPRESSION SPAT REQUIREMENTS

FROM HIP TO BALL OF ANKLE IS ACCEPTABLE LENGTH



NO ANKLE SPAT SUPPORTS



NO OPENINGS ON SPAT PANELS

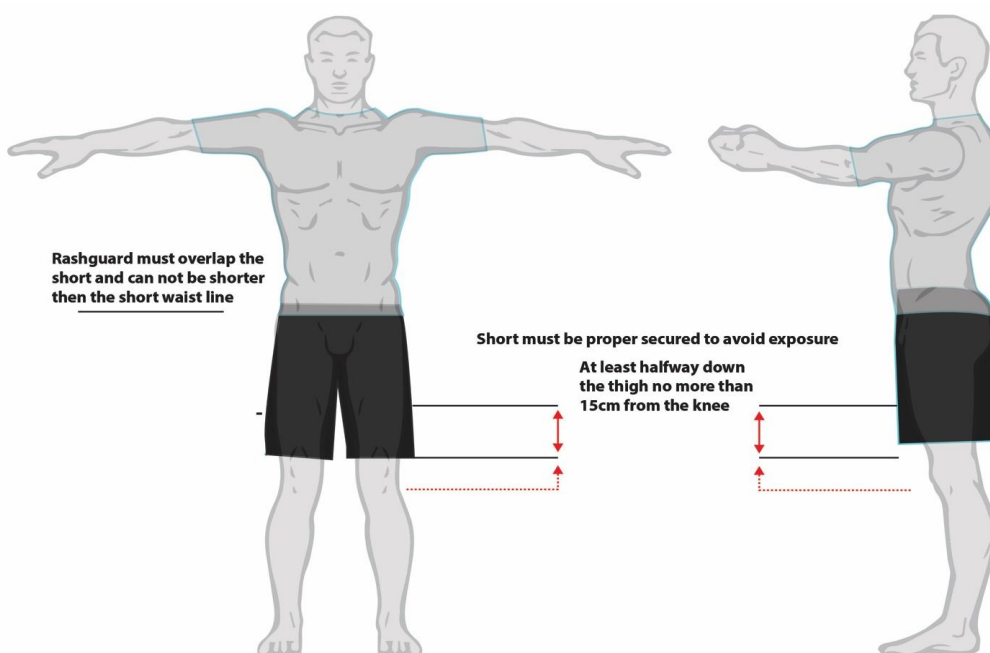

## Article 36 Reporting for Competition

- 36.1 **Weighing In:** For every SJJIF tournament, athletes must report to the weigh-in area in a timely fashion. Competitors should be dressed in their competition uniform, ready to step on to a calibrated scale, and weighed in at the time their division is scheduled to begin. Tournament schedules will be available to all registrants at least 1 day before the tournament begins. See Article 34.1-33.9 for additional information on Weight Divisions.
- a) For each division, all athletes must be weighed in before the division begins. Athletes will be taken to their weight division's designated mat area immediately after they weigh in and will be expected to be ready to compete immediately after weighing in. Divisions will begin as soon as the final athlete has been weighed in.



- b) All athletes must weigh in with their uniform on. At the time of weigh in, all athletes must weigh less than the weight specified for their division or they will be disqualified.
- c) The SJJIF suggests that athletes do not attempt to “cut weight” by dehydrating themselves before weighing in. Athletes will not be given time to recover or rehydrate after weigh-ins. Athletes should be ready to compete at the time they weigh in. Those who dehydrate themselves are at a heightened risk of fatigue and injury.
- d) **Failure to appear for weigh-in:** Should an athlete fail to appear for weigh-in during the official weigh-in period, it will be noted beside his name on the official weigh-in list. A weigh-in official and the SJJIF delegate shall sign the notation. The athlete will be disqualified from competing in that weight category.
- e) **Failure to weigh-in within the prescribed limits of a category:** Should an athlete weigh above the prescribed limits for the category in which he/she is entered the exact weight shall be recorded in the normal manner. The weight shall be circled and signed by a weigh-in official. The athlete shall be disqualified from competing in that weight category.
- f) **Failure to comply with official directions or with SJJIF requirements:** If at any stage during the weigh-in period, an athlete fails to comply with the directions of any weigh-in official or an SJJIF official, or fails to comply with the requirements of the SJJIF, the athlete shall be disqualified from participating in the weigh-in and the infraction brought immediately to the attention of the director of the tournament.

36.2 **Hygiene Requirements:** Competitors are expected to meet the following hygiene requirements or they may be disqualified.

- a) Uniform must be washed, dry, and free of unpleasant odor.
- b) Competitor’s toenails and fingernails must be kept short, clean and free from sharp edges or jaggedness.
- c) Individuals with long hair must secure it so that it will not interfere with their performance or that of their opponent’s during a match.
- d) Competitors may not use makeup, hair spray/dye, or any other substance that will come off onto their own GI, the mats or onto their opponent.
- e) Any individual with a transmittable disease, viral, bacterial or fungal, will not be allowed to compete.
- f) An individual with an uncovered cut, sore, rash, wound or lesion will not be allowed to compete. Individuals with cuts, sores, rashes, wounds or lesions that are bandaged may be allowed to compete at the discretion of the medic and tournament officials.

36.3 **Uniform Requirements:** Competitors are expected to meet all the requirements identified in Article 35.1 – 35.13, as appropriate.

36.4 Competitors not present in the warm-up/bull pen area or who have been summoned to the match area will be called up to 3 times to the designated area; they will have 5 minutes to arrive at the designated area. After the third and final call, if the competitor does not present himself or herself, they will be subject to disqualification



## Article 37 Basic Principles for Uniform Inspectors

37.1 Competitors' equipment and uniforms will be checked by an SJJIF official whose title is "Inspector" immediately before or after they step on the scales to weigh in. The inspectors' duties are to verify that competitors meet the requirements of the SJJIF.

- a) Check the identity of the athletes.
- b) Check that the athletes are wearing the correct color of GI.
- c) The GI must not be wet or stained and of a uniform color.
- d) Check that the athletes are wearing the correct belt color.
- e) Check patches and embroidery for size and location.
- f) Check length of the sleeves, which must cover up the full arms including the wrists in the control position.
- g) Check the distance between the sternum top and the lapel crossing point of the jacket vertically. Must be less than 10 cm.
- h) Check with a GI inspection tool the width of the jacket sleeves and lapel width.
- i) Check that the length of the jacket covers the buttocks.
- j) Check the length of the trousers (the ankle bone, the malleolus, must be visible and accessible for checking).
- k) Athletes must wear under garments below their GI, which must be below the belt level and should not go past the knee, except if it is a separate protection, made of soft material. The protection should not appear below the GI trousers.
- l) Check that female competitors are wearing a form of sport bra.
- m) Long hair must be tied up with a non-metallic hair tie.
- n) If an athlete presents themselves with a tattoo mentioning political, religious or sporting bodies or promoting tobacco, alcohol, any prohibited substances listed in the doping code or contrary to good moral and ethical customs, it should be covered with an adhesive bandage or medical tape.
- o) Check that male athletes are wearing rash guards only on the top part of their bodies.
- p) Protective clothing (knee pad, elbow pad, shin pads etc.) may not have any metallic part or any other part made of rigid material. The uniform inspection of the GI is conducted with the protective clothing on. It is not permitted to put it on after the inspection.
- q) Ensure that the athlete is not carrying a prohibited object.
- r) Verify the length of hand and foot nails and personal hygiene of the athlete.



## 37.2 GI Inspection Tool:

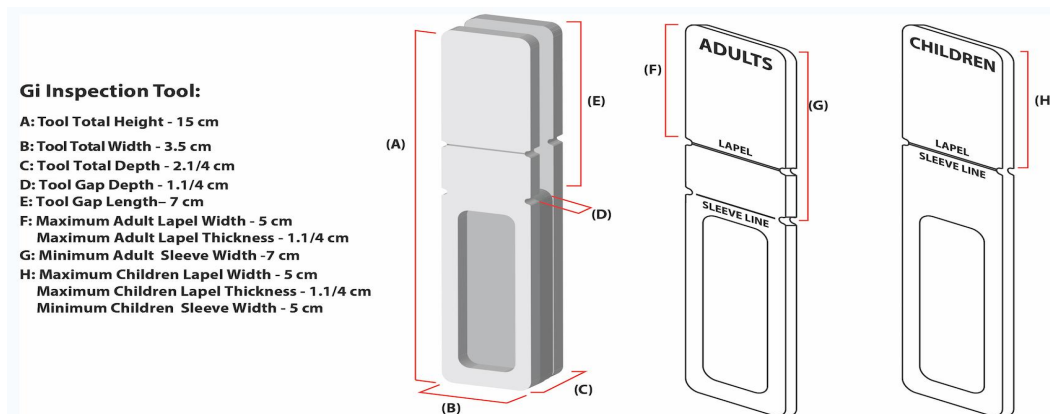

## Article 38 Basic Principles for Referees

- 38.1 Trained and consistent referees are critical to a fair competition as they make decisions that affect the outcome of individual matches. They are expected to enforce the rules and judge matches in an accurate and unbiased manner.
- 38.2 Referees should demonstrate an assuredness in judgments, a characteristic that will come from comprehension of the rules as well as experience. Referees are expected to maintain a calm demeanor regardless of the situation on the mat. This demeanor is not easy and will develop with experience. They are expected to execute judgments without wavering and confusion and they are expected to execute judgments independently from audience influence.
- 38.3 Referees and staff are not permitted to encourage, show favoritism or cheer for any competitor while in the area of competition. Referees who wish to root for a particular competitor must leave the controlled competition area to the spectator area.
- 38.4 Matches will be judged by a single, central referee. The central referee is to remain in the area of combat, close to the competitors so he/she may direct the match. Directing the match ensures that competitors are treated equally and gain no unfair advantage. The mat's central referee is the highest authority on the mat and has the authority to disqualify competitors during the match.
- a) The central referee will oversee that everything is in order; for example: the ring, equipment, GIs, athlete's hygiene, and those scorekeepers are present and ready before starting the competition.
  - b) The central referee is to give the first athlete on the mat a green and yellow belt for identification and keep competitor on the right side. The other competitor must remain on the left side, and after the referee's instructions on positioning; the referee will start the competition by saying "Combate!"
  - c) The referee will not allow interference from outsiders during the match.
  - d) The referee must determine and intervene if there is any possibility the public or photographers pose risk or harm to the competitors during a match.
  - e) A medical team or nurse will be allowed on the mat at the referee's discretion.



- f) The score table will determine expiration of time during the match. The score table will notify the central referee immediately with an auditory and visual signal. The score table will actualize the referee's gestures on a scorecard. The table will display two official scoreboards displaying the score horizontally or a single monitor, which will have colored scores to differentiate the two athletes. During the match persons at the scoring table are not allowed to converse with the competitors.
- 38.5 In special cases, the SJJIF Referee Director can review and overrule a referee decision. The SJJIF Referee Director may also replace a central referee during a match if he/she is deemed unfit to judge a certain match.
- 38.6 Referees must present themselves professionally and appear unified in their appearance, demeanor, and actions. Referees will be held to the same hygiene standards as competitors with a few additional requirements. They should be clean and without odor with well-kept hair. The standard referee uniform will consist of the following:
- Properly fitting solid black slacks;
  - A solid black belt of leathery construction;
  - Solid black socks or shoes which are clean and suitable to be worn on the mat;
  - Solid black polo shirt that is marked with the SJJIF federation logo and the word "Referee" in white so that the markings are visible from the front and the back.
- Special Note: Some events and/or organizations may have additional uniform requirements such as suit and tie.
- 38.7 A solid knowledge and understanding of the rules is crucial for referees. Referees must read and study the book of rules and regulations, attend SJJIF referee seminars, as well as pass required certification courses. Attending referee seminars is essential to developing a solid understanding of the rules and ensuring consistency in scoring as referee directors explain rules and their application in real competition matches.
- 38.8 Extensive Jiu-Jitsu experience is a very important qualification for referees and must be brown or black belts to referee in international competitions. Referees must have an expert level understanding and practice of Jiu-Jitsu to facilitate familiarity with techniques and their counters and escapes, names of Jiu-Jitsu techniques such as "De la Riva guard" and "Omoplata" as well as the names of many Judo techniques such as "O Soto Gari" and "Juji-Gatame", and familiarity with new Jiu-Jitsu techniques and strategies.
- 38.9 Referees are expected to cultivate experience teaching Jiu-Jitsu. Teaching Jiu-Jitsu techniques, their counters, escapes and combinations in addition to takedowns and competition strategy helps referees understand the sport that they officiate.
- 38.10 Referees are expected to have experience as a competitor and as a coach to be better equipped to interpret and anticipate the actions of the competitors, conduct matches in a more informed manner, and understand how to effectively command and judge the competitors.
- 38.11 Referees are encouraged to direct competitors vocally before penalizing them. Referees should liberally and fairly utilize the following commands and others to warn competitors that they are stalling or may be about to commit a foul:



- a) "Ação"
- b) "Lute"
- c) "More action"
- d) "Work to improve"
- e) "Release the illegal grip"
- f) "Don't reap the knee"
- g) "Don't pull the neck"
- h) "Do you want to continue?"

**Article 39 Grading of Referee Performance**

39.1 It shall be the duty of the SJJIF Referee Director to grade each event referee's performance for each contest presided over by the referee. Guidelines for grading are as follows:

- a) The grade shall be either satisfactory or unsatisfactory and shall be arrived at by considering, among other things, the Referee's reflexes, and overall ability to direct and control the contest in a manner designed to ensure the protection of the participants and to obtain the athlete's compliance with the statutes and rules of the SJJIF applicable to the particular event.
- b) The Referee Director may include written comments where the satisfactory grade is rendered but shall make specific written comments where grade of unsatisfactory is rendered. The grade and any comments pertaining thereto shall be filed to the respective SJJIF representative.

**Article 40 Gestures for Referees**

40.1 The central referee will wear an armband on his right wrist (a green and yellow band) to distinguish his hand gestures between competitors. The points indicated with the right hand will correspond to the competitor wearing the green and yellow belt. The points indicated with the left hand will correspond to the competitor who is not wearing the green and yellow belt. As a match progresses, the referee will raise hand to signal the scoring competitor's points to the scoring table.

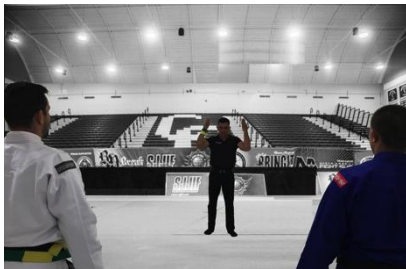

**Permission to enter the mat:** The referee will raise both arms indicating to both athletes that they should enter the mat area.



**Saluting the referee:** Athletes must salute the referee by shaking hands upon entering the mat area.





**Shaking competitor's hand:**  
Before and after a match, both competitors must shake each other's hand regardless of match results.



**Starting the competition:** The referee will position the competitors and as they face each other in the middle of the mat, the referee will raise his arms at the height of his shoulders and then let them drop thus signaling the start of the match while simultaneously saying, "Fight" or "Combate"!



**Take downs, sweeps, knee on the belly, and unintentional out of bounds while in a submission:** The referee will raise his hand indicating the scoring athlete's color and raise two (2) fingers to signify the issue of two points to that athlete's score.



**Passing the guard:** The referee will raise his hand indicating the scoring athlete's color and raise three (3) fingers to signify the issue of three points to that athlete's score.





**Front mount, back mount, and taking the back:** The referee will raise his hand indicating the scoring athlete's color and raise four (4) fingers to signify the issue of four points to that athlete's score.



**Count of 3:** The referee will lower his hand indicating that he has opened the count of three (3) seconds for stabilization prior to awarding points for the following: sweep, knee on belly, passing the guard, mount, back mount, and taking the back.



**Penalties:** The referee will turn his hands one over the other with both fists closed then raise a fist indicating the penalized athlete's color.



**Pausing the match & time:** The referee puts his hands one above the other forming a "T", signaling the timekeeper to pause the time and say "Time" or "Tempo".



**Stalling:** The referee will grab each forearm with his hands and verbally warn the competitor who is stalling and say "work to improve" "Lute", or "Ação".





**Rotate:** The referee will raise one finger and rotate it clockwise to indicate to the athletes that they must keep their match within bounds of the mat area.



**Fix your GI:** The referee will cross each arm, forming an "x" at waist level indicating to the competitor to adjust GI.



**Tie your belt:** The referee will pull an imaginary belt at waist level indicating to the competitor to tie their belt.



**Get up:** The referee will raise an arm indicating to the competitor to stand up.



**Get down:** The referee will lower an arm indicating to the competitor to lie down.





**Disqualification:** The referee lifts his arms above his head and cross them with his fists closed. After that, he points to the disqualified athlete's belt with the hand signifying that athlete's color.



**Removing erroneously awarded points:** The referee lifts the arm that he gave the point with and waves his palm towards his head to indicate to the table that previously awarded points were incorrectly awarded and must be removed.



**Interrupting the competition:** The referee opens his arms together on a horizontal plane level with his shoulders and says "Stop!" or "Parou!" The referee may also place his hands on both athletes and say "Stop!" or "Parou!"



**Announcing winner of match:** The referee will raise the arm of the winning competitor to indicate who has won the match.

## Article 41 Conclusion to Matches

41.1 No match may end in a draw, all matches will be decided by:

- |                            |  |
|----------------------------|--|
| a) Points                  | f) Inability to Continue                                   |
| b) One Man Bracket Result  | g) Unconsciousness   |
| c) Submission              | h) Referee Decision (only in the event of a double injury) |
| d) Disqualification        |  |
| e) "Sudden Death" Overtime |  |



- 41.2 **Victory by Points:** The referee will stop the match at the end of regulation time. If there is no submission or other match conclusion by the time limit of a match, the athlete with the greater number of points will be declared the winner.
- 41.3 **Victory by One Man Bracket Result:** In this case, the competitor in that bracket will receive the gold medal, however no points will be awarded for the individual or team.
- 41.4 **Victory by Submission:** If the referee observes a competitor submitting with physical or verbal signals, the referee will end the competition and award the victory to the other competitor regardless of the point tally.
- The referee may also choose to stop the competition and declare a submission if he/she notices a competitor in immediate physical danger from a properly applied technique.
  - For children divisions, referees will always step in when a child competitor is in immediate physical danger.
  - For adult divisions, referees will be significantly more prudent when exercising the right to stop a competition. For the vast majority of cases in adult matches, the referee will allow submissions to continue until one competitor signals submission.
- 41.5 An athlete may signal submission with the following:
- Tapping with the palm against any surface in a visible manner.
  - Tapping with the feet against any surface if the competitor is unable to use the hands to tap.
  - Requesting verbally to the referee that the competition be stopped (if athlete can neither tap with hands or feet).
  - Requesting that the competition be stopped if the athlete gets injured or feels physically incapable or unprepared.
  - A coach of one of the competitors may request that the competition be terminated by directing themselves to the referee for any reason.
  - When the competitor is under a submission position and he/she screams or emits noise expressing pain or verbalizes the interjection "Aa!" it will be considered the equivalent of the athlete having tapped.
- 41.6 **Victory by Opponent's Inability to Continue:** The referee may end the competition when one of the competitors is injured or if the medical attendant examines the competitor and declares athlete unable to continue. If this occurs, the victory will be given to the opponent as long as the injury was not caused intentionally by conduct worthy of disqualification.
- When a competitor verbalizes that he/she is experiencing muscle cramps or spasms, it could be considered the equivalent of the athlete submitting.
- 41.7 **Victory by Opponent's Loss of Consciousness:** An athlete shall be declared to have lost the match upon losing consciousness due to a legal hold applied by the opponent or due to an accident not stemming from an illegal maneuver by the opponent.



a) Athletes who lose consciousness because of head trauma (concussion) shall not be allowed to compete again in the same tournament and should be directed to undergo treatment from medical staff.

41.8 **Referee Decision/Double Injury:** If both competitors are injured and cannot continue the match, the athlete leading on scorecard shall be declared the winner. If the score is tied and both cannot continue, then the referee must render a decision based on fighting spirit, superiority of tactics, and superiority of techniques. In all other situations, both competitors will be disqualified from continuing since they cannot continue to compete.

## Article 42 The Point System





42.1 Competition makes athletes utilize their technical abilities as they attempt to submit or neutralize their opponents. Points are awarded to determine superior positions or techniques during the match. Superior technique is displayed by maneuvering to achieve superior position.

42.2 The competitor cannot score new points when he/she intentionally removes and returns to and from a position where points have been recently received (changing position intentionally and then returning to the same position). Example: Going up and down into the knee on belly position unopposed will not result in multiple point awards.

42.3 No points will be awarded for a competitor who attains a position while in a submission. Points will only be awarded after the submission is completely defended. Example: When a competitor is mounted on the opponent but is stuck in a guillotine, the points of the mount will only be awarded after the competitor has freed themselves from the guillotine submission attempt, and only if the athlete is still in the mount position.

42.4 The SJJIF does not use an “advantage” point system; we believe this method adversely affects the overall turnout of the match and does not benefit the competitors. An almost point is not the same as an attained point for completing a full maneuver on an opponent. No match will be decided by referee, it will be decided by submission or points, and in the case of a tie, by “sudden death” overtime. For more information see Article 46.2.

42.5 Points are awarded to the competitor by the referee for the following actions:

Points	2 points	3 points	4 points	-1 point
<b>Event</b>	Takedowns Sweeps Knee on Belly	Passing the Guard	Mount Back Mount Back Control	Penalties
<b>Hand Signal</b>				



42.6 **Takedowns (2 Points)** A takedown occurs when a competitor completes an action that drops the opponent from a standing position on their side, butt or back or forces the opponent to their knees or chest and acquires a position behind or on top of the opponent. Points for takedowns are awarded immediately. Guidelines for takedowns are as follows:

- a) A take down which places a competitor outside the designated competition area and onto the security area, will be considered a valid takedown so long as the competitor that executed the move stood with both feet in the competition area while executing the move.
- b) If one competitor grabs a leg or attempts a takedown (i.e. a double leg) and the opponent pulls guard, the competitor will be awarded 2 points for the takedown.
- c) If one of the competitors has one of his/her knees on the ground and is taken down, whoever applied the takedown will be awarded points as long as the opponent has both feet on the ground.
- d) When the competitor attempts any take down and the opponent simultaneously reverses the take down by getting on top, points will be determined by:
  - i. If neither opponent has fallen onto the mat yet, the opponent that lands on top receives the 2 points.
  - ii. If the opponent falls down in a guard position and immediately gets swept, s/he will get awarded the 2 points for takedown and the opponent will receive a 2-point sweep after remaining in position for 3 seconds.
  - iii. If the opponent falls down in side control or mount position and immediately gets flipped over, s/he will get awarded the 2 points for the takedown and the opponent will not receive any points.

#### Example of Takedowns



**Hip Toss Sequence**



**Single Leg Sequence**





Lateral Suplex Sequence

### Example of Takedown Allowed for Brown and Black Belts Only



Scissor Takedown Sequence

### Examples of Illegal Takedowns



Suplex Takedown Sequence



### Example of Inside of Bounce Takedowns



### Example of Out of Bounce Takedowns



42.7 **Knee on Belly (2 Points)** A knee on belly occurs when the competitor on top is in side control and puts his/her knee on the opponent's belly while holding the collar or sleeve and belt with their hands and the other leg is up and a foot posted on the mat for 3 seconds.

- a) If the competitor that is underneath does not allow the adversary to put his/her knee down onto the belly and if the competitor on top does not establish the position completely for a count of 3, then points will not be awarded.

### Examples of Correct Knee on Belly



### Examples of Incorrect Knee on Belly



42.8 **Sweep (2 Points)** A sweep occurs when the competitor that is underneath has the opponent in a form of guard and is able to get on top of the opponent by inverting his/her position. Guidelines for sweeps are as follows:

- a) In order for a competitor to be awarded points for a sweep, the opponent must have a form of guard established. The guard is considered any position where the competitor is on his/her back, side, or turtle position using one or both legs to keep distance or control over the opponent. If a competitor is using his/her legs to keep distance or control of the opponent, then the opponent is considered 'in guard.'
- b) Turtle guard will only be considered a guard position when it was established from a preexisting guard position.
- c) A sweep can be done with the use of arms or legs.
- d) Points for sweeps will only be awarded after a competitor goes from a guard position and establishes a position on top of the opponent for a count of 3 seconds.
- e) When a competitor who is sweeping gains top position and advances his/her position to the back of the opponent during the attempted sweep, the competitor will be awarded 2 points for the sweep and 4 points for the back as long as the criteria for both actions are fulfilled.
- f) If starting in a guard position while a competitor attempts a sweep, both competitors must return to their feet, and the competitor attempting the sweep executes a takedown while remaining on top, he/she will be awarded points.
- g) If the competitor on top tries to go for a submission while inside of a guard position, and ends up under his/her opponent, his/her opponent will be awarded 2 points for a sweep after escaping the submission and maintaining a top position for 3 seconds.
- h) If the competitor on the bottom attempts a submission from the guard and lands on top of opponent and stabilizes position for 3 seconds the athlete will be awarded the sweep and 2 points.
- i) If a competitor is passing the guard and falls prior to referee's open count for guard passing or mount, and the opponent on bottom ends up on top, the opponent will be awarded 2 points for a sweep after stabilized for 3 seconds.
- j) If a competitor from the guard arm drags his/her opponent going to the top onto a turtle position, the competitor will receive 2 points for a sweep after having controlled for 3 seconds.
- k) Sweep attempts using a form of illegal position for the competitor's respective belt or age division will result in negative points or disqualification.
- l) **Double Guard Pull:** If at any point during the match both competitors pull guard with grips from standing at the same time, the first competitor to come to a top position shall be awarded points for a sweep after he/she maintains a controlling position on top of the opponent for a count of 3 seconds. Rules for double guard pull are as follows:
  - i. Both athletes must have grips before pulling guard.



- ii. When both athletes with grip pull guard at the same time, one competitor must acquire a top position within 20 seconds or both athletes will be penalized with a negative point for lack of combativeness/stalling.
- iii. When both athletes pull guard, but only one athlete had a grip while standing the opponent must come up in order to not receive a negative point.
- iv. If both athletes pull guard without establishing grips first, both athletes will receive a negative point.
- v. If an athlete with grips pulls guard and the opponent either pulls guard or sits at the same time but without grips, if the athlete with grips goes up and establishes a top position for a count of three seconds, he/she will be awarded two points for sweep.

### Examples of Guard



**Closed Guard**



**Butterfly Guard**



**Quarter Guard**



**Standing Closed Guard**



**Turtle Guard**



**Inverted Guard**



**Spider Guard**



**Inverted Half Guard**



**50/50 Guard**



### Examples of Sweeps

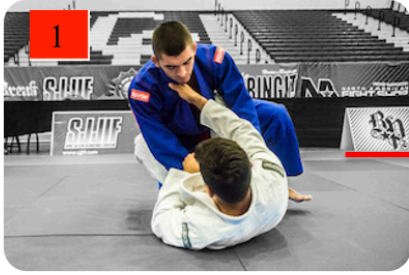

Closed Guard Scissor Sweep

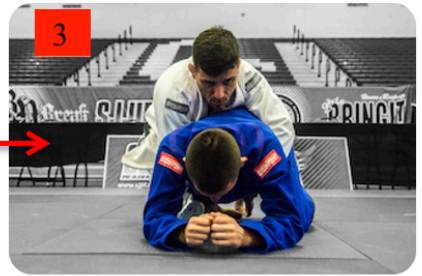

Butterfly Arm Drag Sweep



50/50 Guard Sweep

### Example of Illegal Sweep for KID 1 through KID 6



Guillotine Sweep



Example of Illegal Sweep for KID 1 through KID 4

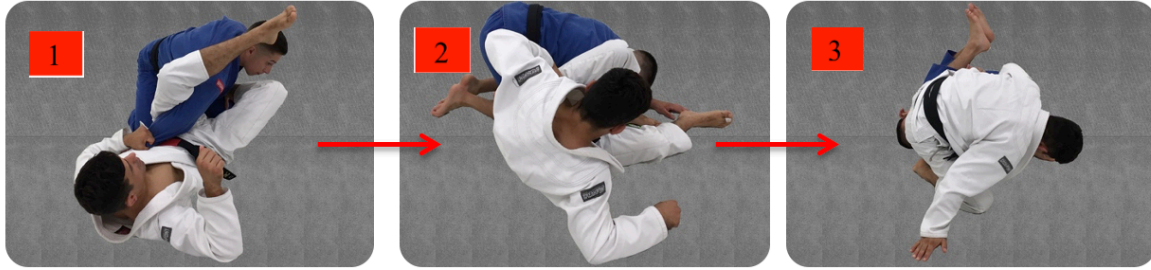

Omoplata Sweep

Example of Legal Sweep for Brown & Black Belt Only

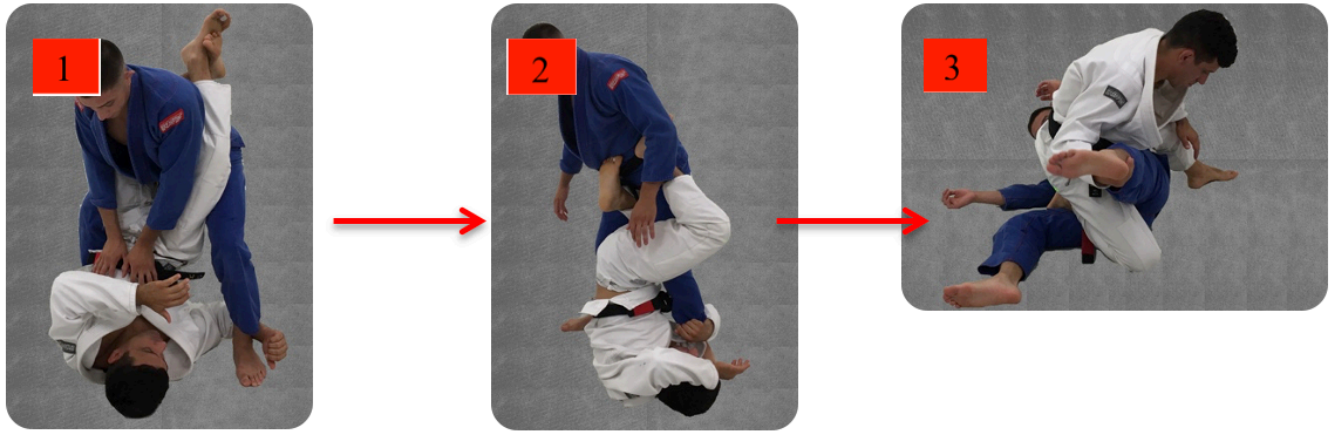

Leg Lock Sweep

Examples of Escapes or Reversals – Not Sweeps



## Examples of Escapes or Reversals – Not Sweeps

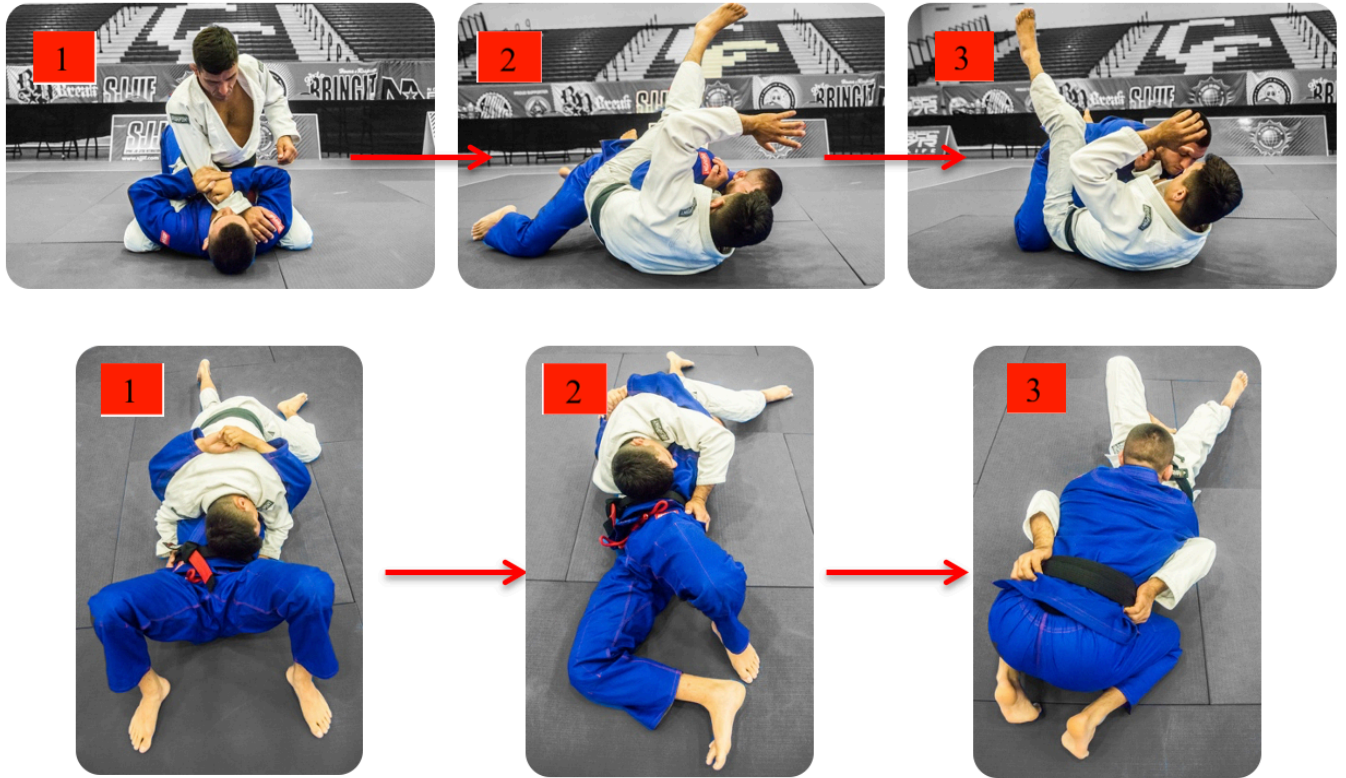

42.9 **Passing the Guard (3 Points)** Passing the guard occurs when a competitor maneuvers from a position where he/she is in the opponent's guard to a perpendicular or longitudinal position where he/she is no longer controlled by the opponent's legs and is using his/her weight to pin the opponent, leaving the opponent no space to move or escape the position. Guidelines for passing the guard are as follows:

- a) In order for a competitor to be awarded points for passing the guard the opponent must have had a form of guard established. It is considered guard any time a competitor is on his/her back or side and is using one or both of his/her legs to keep distance or control of the opponent. If a competitor is using his/her legs to keep distance or control of the opponent, then the opponent is considered 'in guard.'
- b) Points for passing the guard will only be awarded after a competitor has established a controlling position past his/her opponent's guard for a count of 3 seconds.
- c) If the competitor that is underneath avoids the move by putting his/her opponent back in guard or by getting to his/her knees or standing up, no points will be awarded.
- d) If a competitor who was in his/her opponent's guard acquires and establishes the mount position then he will be awarded points for passing the guard and points for mount.



# Examples of Passing the Guard

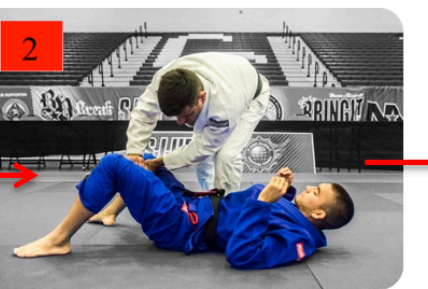

## Examples of Positions Not Considered Guard Pass

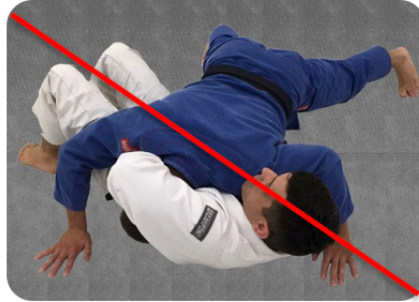
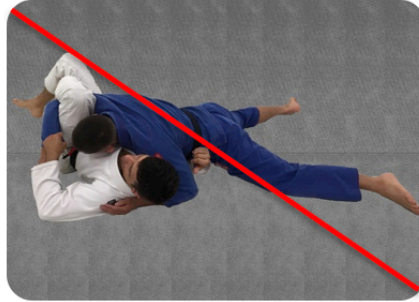

- 42.10 **Mount (4 Points)** Mount occurs when a competitor is facing the opponent's head while sitting on the opponent's torso. The opponent can be lying on his/her back, side or stomach. The one mounting cannot be on top of one or both of the opponent's arms. It will also be considered a mount if one knee and one foot are on the ground. In the case that the athlete mounting has both opponent arms under his legs, the athlete must have the knees below the armpit line in order to receive points. Guidelines for mount are as follows:
- Points for a mount position will only be awarded after a competitor has established the mount position for a count of 3 seconds.
  - No points will be awarded if a competitor's feet or knees are on the opponent's leg.
  - If a competitor applies a triangle while in guard and in so doing lands mounted on the opponent, it will be considered a sweep and not a mount until he/she is in the mounted position.

## Examples of Mount



## Examples of Positions Not Considered Mount



42.11 **Taking the Back & Back Mount (4 Points)** Taking the back occurs when a competitor is in a position where his/her chest is against the opponents back, arms are around his/her neck/shoulders/torso, and legs around the opponent's waist or torso. Guidelines for taking the back are as follows:

- Points for taking the back will only be awarded after a competitor has established a controlling position on the opponent's back for a count of 3 seconds.
- Points will not be awarded if the competitor does not have control of the opponent's body both with the arms and legs. The competitor must position his/her knees around the opponent's waist and his/her ankles against the opponent's inner thighs.
- Points for the back may also be awarded if a competitor has chest-to back control, arms around the neck/shoulders/torso and uses his/her legs to hook one of the opponent's thighs and one of the arms.

## Examples of Taking the Back





Examples of Positions Not Considered Taking the Back

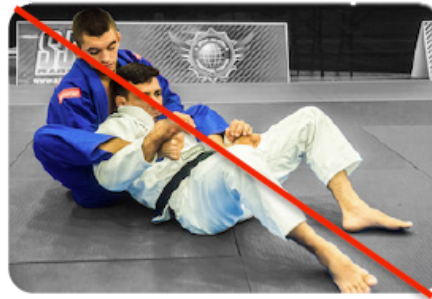
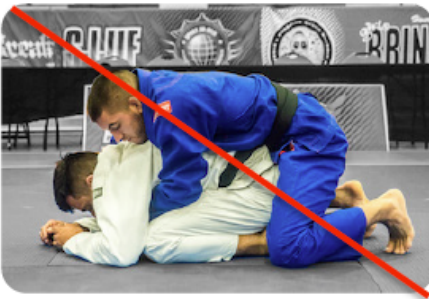

## Article 43 Minor Fouls, Stalling, and Penalty Points

43.1 **Minor Fouls:** Any of the following actions will be considered minor fouls:

- When a competitor kneels, sits or lies down before making contact with the opponent.
- When a competitor runs towards any of the outer boundaries of the competition area, flees while ground competing by crawling or rolling out of the competition area, or stands up to avoid engaging an opponent purposely by stepping out of said area.
- When a competitor on the ground stands to escape combat and does not return to combat on the ground.
- When a competitor breaks the grip of the opponent pulling guard and does not return to combat on the ground.
- When a competitor avoids engaging the opponent by taking off his/her GI or by allowing it to be taken off with the intention of stopping the competition to allow himself/herself to rest or to avoid the attacks of the opponent.



- f) When a competitor intentionally removes his/her own GI or belt, causing the match to be stopped.
- g) When a competitor inserts his/her fingers inside the cuffs of the sleeves or pants.
- h) When a competitor disobeys a referee order.
- i) When a competitor exits the match area following a match prior to the referee announcing the result.
- j) When a competitor grabs hold of his/her uniform or that of his/her opponent in any way during a No GI match.
- k) When a competitor places a hand or foot on his/her opponent's face.
- l) When a competitor takes more than 20 seconds to tie his/her belts during a match stoppage (when a competitor is also using the identification belt).
- m) When a competitor runs around the match area and does not engage in combat.
- n) When a competitor unintentionally reacts in a way that places his/her opponent in an illegal position.

### Examples of Minor Fouls



**Illegal Grip (Inside the pants)**



**Illegal Grip (Inside the sleeve)**

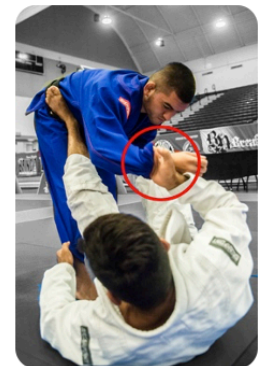

**Illegal Grip (Inside the sleeve)**

#### 43.2 Consequences for minor fouls will be as follows:

- a) On the first offense the offender will be given a verbal warning.
- b) On the second offense the offender will be given a penalty point.
- c) On the third offense the offender will be given a second penalty point, and the referee will restart the fight with both athletes standing.
- d) After the fourth offense the referee will disqualify the competitor.
- e) Brown and Black Belts will receive a verbal command and negative point upon the first offense of a minor foul (not applied to lack of combativeness/stalling).

43.3 **Lack of Combativeness (Stalling):** Lack of combativeness (stalling) is defined by one competitor clearly not pursuing positional progression in a match and also when a competitor impedes his/her opponent from carrying out said progression. If a competitor is stalling, the referee will make the gesture to indicate this and verbally warn the stalling athlete. He may verbally warn the athlete with phrases like: "Lute", "work to



improve”, “you have to move”, or “you have to work.” Any of the following actions will be considered stalling:

- a) Lack of combativeness (stalling) is considered holding the opponent in a position without trying to improve or submit for more than 15 seconds, standing up to disengage the opponent, or any position designed to stall.
- b) When both competitors simultaneously demonstrate a lack of combativeness (stalling) in any position in a match.
- c) When both competitors pull guard at the same time, the referee will start a 20 second countdown. If at end of this 20 second countdown, even if the competitors are moving, if one of the competitors does not reach the top position, does not have a submission in hold, or is not imminently completing a point scoring move, the referee will stop the fight and give a penalty to both competitors. In this situation, the referee will restart the combat in standing position.
- d) Lack of combativeness (stalling) is not declared when a competitor is defending his/herself from an opponent’s attacks from mount, back-control, side-control or north-south positions.
- e) Lack of combativeness (stalling) is not declared when a competitor is in mount or back position, as long as the characteristics of the technical position are respected.

**43.4 Examples of situations constituting lack of combativeness (stalling) are as follows:**

- a) When a competitor, upon achieving side-control or north-south positions over an opponent, does not seek positional progression.
- b) When a competitor in an opponent’s closed guard does not seek to pass guard and at the same time prevents the opponent from seeking positional progression from guard.
- c) When the bottom competitor playing closed guard wraps his/her arms around the opponent’s back or performs any other controlling movement clutching the opponent to him/her without intending to achieve a submission or score.
- d) When a competitor on foot grabs and maintains their hand on the opponent’s belt, preventing the opponent from completing a takedown movement without attempting an attack of any kind.
- e) The aforementioned examples are merely illustrative and do not represent all the situations that may be deemed lack of combativeness (stalling).

**43.5 Consequences for stalling will be as follows:**

- a) On the first offense the offender will be given a verbal warning (“lute” + 15 seconds)
- b) On the second offense the offender will be given a penalty point. (“lute” + 1 negative point + 15 seconds)
- c) On the third offense the offender will be given a second penalty point, and the referee will restart the fight with both athletes standing. (“lute” + 1 negative point (total of 2) +15 seconds)
- d) On the fourth offense the referee will disqualify the competitor. (1 negative point (total of 3) +disqualification)



- e) Brown and Black Belts will receive a verbal command and negative point upon the first offense of a minor foul (not applied to lack of combativeness/stalling).

43.6 **Penalty Procedures for Minor Fouls and/or Stalling on Score Board are as follows:**

- a) Penalty points accrued for both minor fouls and stalling are combined, and upon the third penalty point a competitor will be disqualified.
- b) Brown and Black Belts will receive a verbal command and negative point upon the first offense of a minor foul (not applied to lack of combativeness/stalling).

Minor Foul Count	Referee Action	Score Board
1 <sup>st</sup> offense	Gives first penalty point	Mark on score board (-1)
2 <sup>nd</sup> offense	Gives second penalty point	Mark on score board (-2)
3 <sup>rd</sup> offense	Gives third penalty point	Mark on score board (-3)

- c) Score board procedure for White through Purple Belt for Minor Foul and/or Stalling and Brown through Black Belt for Stalling Only

Minor Foul and/or Stalling Count	Referee Action	Score Board
1 <sup>st</sup> offense	Verbal warning	No mark on score board
2 <sup>nd</sup> offense	Gives first penalty point	Mark on score board (-1)
3 <sup>rd</sup> offense	Gives second penalty point	Mark on score board (-2)
4 <sup>th</sup> offense	Gives third penalty point	Mark on score board (-3)

**Examples of Scoreboard**



Competitor 2 receives first (-1) negative point



Competitor 2 receives second (-2) negative points

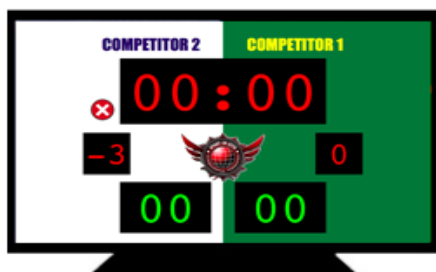

Competitor 2 receives third (-3) & final negative points



- 43.7 **Unintentional Out-of-Bounds during Submission (2 Points)** Occurs when a competitor unintentionally goes out of bounds while trying to escape from a submission. The referee will stop the competition, bring the competitors back to the center of the mat and restart the competitors from the standing position. The competitor who had been applying the submission when the unintentional out of bounds occurred will be awarded 2 points.
- 43.8 **Penalty Point (-1 Negative Point)** Occurs when a competitor continues to stall and/or engage in actions considered minor fouls after a verbal warning from the referee. Each penalty point awarded to a competitor will count as single points subtracted from the final score. At the third negative point the referee will disqualify the competitor.

## Article 44 Legal & Illegal Techniques & Submissions

44.1 The following are allowed submissions according to belt ranks and/or age divisions:

(Techniques marked X are illegal)	KID 1 through KID 4	KID 5 through KID 6	Juvenile and above White Belts and Beginners	Juvenile and above Blue, Purple Belts and Intermediate	Adult and above Brown, Black Belts and Advanced
Spinal Lock, Cervical Lock, or Neck Crank	X	X	X	X	X
Suplex takedown technique, throwing the opponent's head or neck to the ground.	X	X	X	X	X
Slamming from the Guard	X	X	X	X	X
Slamming to Escape a Submission	X	X	X	X	X
Bending fingers backwards	X	X	X	X	X
Bent Knee Lock	X	X	X	X	X
Lateral Leg Lock	X	X	X	X	X
Reaping the Knee	X	X	X	X	X
Straight foot lock, turning inward forcing the knee	X	X	X	X	X
Outward toe hold, applying outward pressure to the knee	X	X	X	X	X
Heel Hook	X	X	X	X	X
Bicep Lock or slicer	X	X	X	X	
Calf Lock or slicer	X	X	X	X	
Knee bar	X	X	X	X	
Toehold	X	X	X	X	
Sock Lock	X	X	X	X	
Scissor Takedown	X	X	X	X	
Straight Ankle Lock	X	X			
Front Guillotine	X	X			
Wrist Lock	X	X			
Frontal Ezekiel Choke	X	X			
Do-Jime (squeezing the body or head with the legs)	X	X			
Pulling on the Head in the Triangle	X				
Omo-plata	X				



44.2 The Kid 4- 5 through Kid 6 divisions are not allowed to apply any form of submissions, locks, or stretches from the waist down.

### Examples of Allowed Submissions for All Belts or Age



**Cross Choke**



**Triangle Choke**



**Back Triangle Choke**



**Kimura**



**Rear Naked Choke**



**Americana**



**Back/Cross Choke**



**Armbar**



**Armbar**



**Mount Triangle**



**Face Down Choke**



**Anaconda (Not bending cervical)**



Examples of Allowed Submissions for All Belts Kid 5 Division and Up



**Omoplata**



**Pulling the Head in a Triangle**



**Gogoplata**

Examples of Allowed Submissions for All Belts Juvenile Division and Up



**Squeezing the Head**



**Darce Choke**



**Guillotine Choke**



**Wrist Lock**



**Straight Foot Lock**



**Do-Jime**

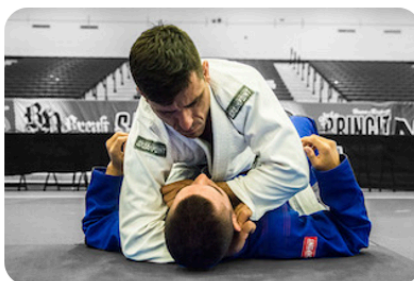

**Frontal Ezekiel Choke**



## Examples of Legal Technique/Position When Attempting to Foot Lock



**Outside foot lock while crossing over the opponents opposite leg.**



**Crossing opponent's leg below the knee.**



**Straight Foot Lock**



**Outside Straight Foot Lock**



**Crossing the opponent's leg without reaping the knee.**

## Examples of Allowed Submissions for Brown or Black Belts Only



**Bicep Lock**



**Leg Lock**



**Leg Lock**



**Calf Lock**



**Bicep Lock**



**Toe Hold**





**Knee Bar**



**Leg Lock**



**Toe Hold**



**Sock Lock**



**Sock Lock**

#### 44.3 Illegal Techniques:

- a) **Juveniles and Above** The use of an illegal technique for a given age/skill division will result in an immediate disqualification of the competitor by the referee.
- b) **Kids 6 and Under**
  - i. If a kid applies an illegal technique for the first time during a match, the referee will stop the fight and undo the illegal move. An educational penalty (negative point) will be given, and the match will resume at the referee's instruction.
  - ii. In the case where the young athlete repeats the use of the illegal technique the offender will be disqualified.
  - iii. In the event of a kid tapping from an illegal technique before the referee has a chance to stop the match the offender will be disqualified.
  - iv. In the event where a young competitor uses an illegal technique and acquires a superior position the referee will stop the match and return the competitors to the position prior to the illegal technique being in place. An educational penalty (negative point) will be given and the match will resume at the referee's instruction.
- c) **All Ages** In the case where the referee is able to stop the illegal technique before it effects the outcome of the match the referee may only give a warning. For example, a beginner or intermediate competitor ends in an unintended knee-reap position after a scramble such as escaping from the mount and the referee can pause and remove the knee-reap before restarting the match.



Examples of Illegal Techniques for All Belts and Ages



Spinal Lock, Cervical Lock, or Neck Crank



Spinal Lock, Cervical Lock, or Neck Crank



Spinal Lock, Cervical Lock, or Neck Crank



Spinal Lock, Cervical Lock, or Neck Crank



Spinal Lock, Cervical Lock, or Neck Crank



Slamming from the Back



Slamming from the Guard



Suplex takedown technique, throwing the opponent's head or neck to the ground.

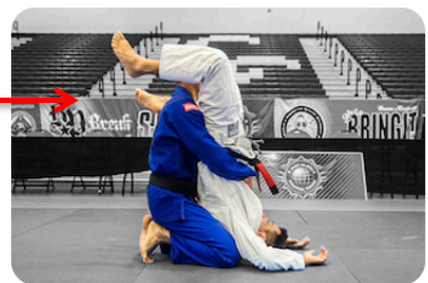
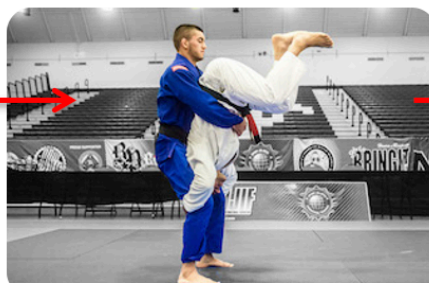

Throwing the opponent's head or neck to the ground.





**Heel Hook**



**Lateral Leg Lock**



**Bent Knee Lock**



**Reaping the Knee**



**Outward toe hold, applying outward pressure to the knee**



**Straight foot lock, turning inward reaping the knee**



**Straight foot lock, turning inward and reaping the knee**



**Grabbing/Bending fingers backwards**

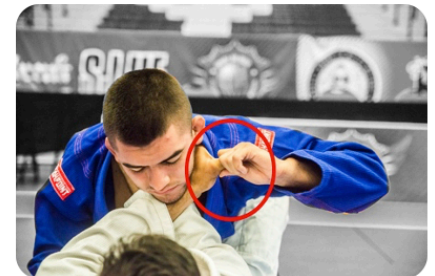

**Grabbing or Bending Thumb of the Finger Backwards**

## Article 45 Serious Fouls & Disqualification

45.1 **Serious Fouls:** Serious fouls will lead to immediate disqualification by a referee. The actions that are considered serious fouls are as follows:

- a) Putting fingers into the eyes or nose of one's opponent.
- b) The use of fists, feet, knees, elbows, or head butting with the intention to hurt or gain unfair advantage (e.g., punching, kicking)
- c) When an athlete bites, pulls hair, strikes or applies pressure to the genitals or eyes, or intentionally uses a traumatic blow of any kind (such as punches, elbows, knees, head butts, kicks, etc.).



- d) When an athlete directs profane language, obscene gestures, or disrespectful behavior at his/her opponent, the center table, table officials, referee or public during a match or in celebrating victory.
- e) When one or both athletes disregard the seriousness of the competition by performing actions simulating or faking combat.
- f) When athlete holds to a submission after an opponent has tapped and referee has told the athlete to stop and let go of the submission try to intentionally hurt his opponent.
- g) When an athlete uses his/her own belt or the opponent's belt to assist in a choke or any other circumstance in a match while the belt is untied.
- h) When an athlete strangles his or her opponent, without using the GI, with one or both hands around the opponent's neck or applies pressure to the opponent's windpipe using the thumb.
- i) When an athlete blocks the passage of air to his/her opponent's nose or mouth using his/her hands.
- j) When an athlete intentionally attempts to get his or her opponent disqualified by reacting in a way that places his or her opponent in an illegal position.
- k) When an athlete deliberately flees the match area to avoid submitting to a submission hold applied by his/her opponent.
- l) When an athlete's GI is rendered unusable and he/she is unable to exchange it for a new one within a period of time stipulated by the referee.
- m) When it comes to a referee's attention that an athlete is not wearing an undergarment under his or her uniform as outlined in the SJJIF Rulebook Article 35.
- n) When an athlete applies creams, oils, gels or any slippery substance to any part of the body.
- o) When the athlete utilizes any substance that makes the kimono slippery for the grips.
- p) The suplex movements that will project or force the opponent's head or neck into the ground. Note: The suplex takedown is defined as the attacking of an athlete by lifting the opponent at the waist in order to take him/her down, by throwing him backwards or sideways to the ground. The use of this technique is still permitted provided that the movement does not force the opponent's head or neck into the ground.
- q) When an athlete applies a hold prohibited for their respective division, as indicated in Article 44.1
- r) Vomiting
- s) Passing excrement

45.2 **Disqualification:** An athlete may be disqualified at any time for committing a serious foul or utilizing an illegal technique as determined by their age and skill division. Guidelines for disqualification are as follows:

- a) An athlete will be disqualified by the third time he/she commits a minor foul.
- b) Competitors that do not show to the warm-up/bull pen area and have been summoned to the match area will be called up to 3 times to the designated area; they



will have 5 minutes to arrive to the designated area. After the third and final call, if the competitor does not show they will be subject to disqualification.

- c) If one of the competitors does not show up for a given match, the competitor present will be awarded the win. The competitor who is not present will not receive a medal or classification.
- d) Competitors who are not waiting for a match or unauthorized spectators who are inside the specified competition area will warrant disqualification of the corresponding competitor at the discretion of the referee.
- e) Competitors who are disqualified by a serious foul in the Semi-Finals will not be allowed to compete for third place.
- f) Competitors who are disqualified by a serious foul in the Finals will not receive a medal and will not be awarded team points.

#### **Article 46 Out of Bounds & "Sudden Death" Overtime**

**46.1 Out of Bounds:** During the match it is the referee's responsibly to direct the competitors towards the center of the mat area. In the event that the competitors move out of bounds during the match, the referee will gesture and call out "stop" or "parou" and competitors shall hold their position without movement. Guidelines for Out of Bounds are as follows:

- a) Both competitors will be considered out of bounds if 2/3 of either competitor's body is outside the boundary.
- b) The referee may be assisted by the timekeeper in moving the athletes back to the center of the mat area or the athletes may be asked to walk back to the center.
- c) The referee will restart athletes in the center of the mat area in the same position or in the standing position.
- d) The event time is placed on hold from the moment the referee declares, "stop" or "parou" until the match resumes.
- e) No points will be awarded for movements or positions after a referee has called "stop" or "parou".
- f) After a referee calls "stop" or "parou", points may only be awarded after the referee signals to resume the match.
- g) In the case of the competitors going out of bounds during a scoring action such as a sweep or dominant position with no part of the head of either competitor out of the protection area, the referee shall wait the 3 seconds count before stopping the action then restart the match in the center with competitors in the same position, and award points.
- h) In the case where competitor A goes for a sweep on competitor B, and competitor A acquires a top position but competitor B runs out of bounds without competitor A acquiring a secured position the match shall restart in the standing position and competitor A will receive the 2 points for the sweep.



46.2 **“Sudden Death” Overtime:** When there is a tie situation on the scoreboard at the end of the match-time, the referee will call for a tiebreak “sudden death” match. Guidelines for “Sudden Death” overtime are as follows:



- a) The referee will place both opponents in a starting position and will restart the competition for a non-regulated time period.
- b) Application of rules and negative points for stalling will be more rigid during a “sudden death” match.
- c) Athletes must actively pursue points and/or submission during match.
- d) When a competitor scores points or forces the opponent to submit during sudden death overtime, the referee will end the match immediately. The first competitor to have scored points or forced the opponent to submit will be declared the winner.
- e) If a competitor receives a negative point during “sudden death” overtime, the referee will end the match immediately and declare his/her opponent the victor.
- f) If one or both competitors are stalling, referee may give negative points to both athletes.
- g) If there is not enough action from both competitors the referee may do the following:
  - i. If there is insufficient action from a standing position, restart the competitors in the center of the mat in a standing position.
  - ii. If there is insufficient action from a standing position, restart the competitors in the center of the mat area with athletes starting on their knees.
  - iii. If there is continued insufficient action from both athletes the referee can potentially end the match with double disqualification in the case of a third negative point awarded to both athletes.
- f) A competitor that pulls guard and does not show significant attempts to submit and/or gain points can be seen as avoiding the match, which can result in losing points.
- g) A competitor that runs away from the opponent’s guard in an attempt to call the fight to the feet and/or does not show significant attempts to pass the guard can be seen as avoiding the match which can result in losing points.
- h) The center referee and/or Referee Director may ask for a three (3)-referee set-up if deemed necessary.

## Article 47 Medical Timeouts and Injury Procedures

### 47.1 Medical Timeouts:

- a) **Bleeding:** If a competitor begins bleeding during a match the referee will immediately stop the time, separate the competitors, placing the non-injured competitor on his knees to wait, and signal to a medic present at the tournament to assist the bleeding competitor. Once the bleeding is under control, the match may continue. Guidelines for bleeding are as follows:



- i. The Medic may treat the same bleeding injury on two (2) occasions. The third (3rd) time that the same bleeding injury occurs, the Referee shall end the contest for the athlete's own safety and shall declare the opponent to be the victor.
  - ii. At the discretion of the referee and the medic, the match may be stopped if the cut or bleeding is too severe and cannot be contained with the appropriate dressing or tape.
  - iii. Blood must be cleaned immediately from uniforms and mat surfaces. The medical personnel must then clean surface with chloride type germicidal.
- b) **Injuries:** If a competitor complains of an injury during a match, the referee will stop the match and call the medic to attend to the injured competitor. It is important to note that this may be considered the same as verbally tapping out to a submission.

Guidelines for injuries are as follows:

- i. The Medic may declare that the injured competitor can continue without danger to their health, and if agreed by the Referee the match continues.
  - ii. The Medic may declare that the injured competitor cannot continue because their health is in danger. The Referee may declare the injured competitor the loser if the injury was the result of an act that would not have resulted in a penalty for the attacking competitor (must be able to continue within 1 minute) or the Referee may declare the injured competitor the winner if the injury was of a prohibited act outlined in this rulebook.
  - iii. The Medic may declare that the injured competitor cannot continue at a result of an attack and of a pre-existing condition (i.e. asthma, physical ailment). The Referee may declare the injured competitor the loser if the injury was the result of an act that would not have resulted in a penalty for the attacking competitor (must be able to continue within 1 minute).
  - iv. If both competitors are injured and cannot continue the match, the athlete leading on scorecard shall be declared the winner. If the score is tied and both cannot continue, then the referee must render a decision based on fighting spirit, superiority of tactics, and superiority of techniques. In all other situations, both competitors will be disqualified from continuing since they cannot continue to compete.
  - v. If it is impossible to determine which of the competitors was the cause of the injury, the athlete unable to continue shall lose the match.
- c) **Sickness:** Generally, if a competitor is taken sick during a contest and is unable to continue, he/she shall lose the match and the opponent will be declared the winner.
- d) **Accident:** If an accident occurs which is due to an outside influence (force majeure), after consulting with the Referee Director, the match shall be considered cancelled or postponed. In those cases of 'force majeure', the Referee Director will take the final decision.

47.2 **Severe Impact to the Head or Back:** The Referee shall call the Medic to attend to an athlete who has received a severe impact to the head or back (spinal column), or



whenever the Referee has reason to believe there may be a grave or serious injury. In either case, the Medic will examine the athlete in the shortest time possible and indicate to the Referee whether the athlete can continue or not. Referees will determine match results in accordance with the guidelines identified in Article 47.1.b.

- 47.3 **Concussions:** A concussion is typically defined as a head injury with a temporary loss of brain function. Symptoms include a variety of physical, cognitive, and emotional symptoms, which may not be recognized if subtle. Fewer than 10% of sports-related concussions are associated with loss of consciousness. A variety of signs accompany concussion including consciousness or amnesia), behavioral changes (such as irritability), cognitive impairment (such as slowed reaction times), or sleep disturbances. It is very important, in case of injury, to abide safety instructions in order to preserve the athlete's health and to ensure an appropriate medical follow-up. Safety guidelines for suspected concussions are as follows:
- a) The Referee shall stop the match immediately.
  - b) The Referee will call the event Medic immediately to examine the athlete. The Medic will
  - c) The athlete should respect the recommended rest period prescribed by the Medic and/or Medical Doctor.
  - d) The athlete should officially inform the SJJIF Medical Commission of injury.
  - e) The athlete should return to activity only when medical clearance has been given.

- 47.4 **Medical Suspension Following Concussion:** Athletes of all age categories with a confirmed concussion by a Medical Doctor or by a relevant event's head of medical services are not allowed to compete within a period of seven (7) days starting the day after the date of injury. Athletes can return to competition having a medical clearing from their team medical doctor, family doctor or any other medical doctor having the authority to issue such a clearing.

## Article 48 Visually or Physically Impaired Competitors in Traditional Competition

48.1 A visually challenged competitor will have the right to choose to start the match with a grip or at a touch. In the occasion that athletes that have a form of disability effecting the leg or foot, that athlete may choose to start match in the sitting position. All other physically impaired competitors will begin a match traditionally.

## Article 49 3 Referees Format

49.1 All black belt matches will be refereed by in a 3 Referees Format.

49.2 Tournament organizers may opt to appoint three referees for a single match whenever deem necessary.

49.3 Guidelines for a 3 Referees Format is as follows:

- a) Two corner referees shall be seated in lightweight chairs placed at opposing corners of the match area and a central referee will stand in the middle of the mat.



- b) The corner referees bear the same powers as the central referee – and all or any points, advantage points or penalty points awarded must be confirmed by at least two of the three referees.
- c) Should there be a consensus between the corner referees and the central referee, the corner referees shall remain seated in the chairs at the corners of the match area.
- d) Should there be a conflict of opinion with the central referee, the corner referees should stand up and signal for points, advantage points or penalty points to be awarded or subtracted, using gestures predefined in this rule book.
- e) If the referee decides to disqualify an athlete due to the athlete's accumulation of three penalties (serious foul or lack of combativeness), the referee will make the serious penalty gesture before stopping the fight. If at least one of the side referees repeats the gesture, the referee's decision is confirmed and he or she is authorized to stop the fight.
- f) If the referee decides to disqualify an athlete due to the athlete committing a severe foul, he will make the gesture before stopping the fight. If at least one of the side referees repeats the gesture, the referee's decision is confirmed and he or she is authorized to stop the fight.
- g) When deemed necessary, the SJJIF will use additional referees coordinator with access to video replay for the correction of awarded points, or penalties on the scoreboard.
- h) After the referee director reaches a conclusion on how to correctly adjust the current score, they will communicate decision to the central referee.
- i) The central and side referees cannot contest the decision reached by the referee director with access to the video replay.











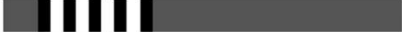
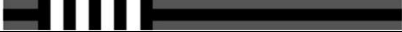

## **Article 50 Adapted Jiu-Jitsu and Special Events**

50.1 National Federations and/or Continental Federations with insufficient number of participants per belt and/or weight divisions have the right to combine weight and/or belt divisions to ensure competition. These events will be considered Special Events and the following guidelines apply to these circumstances:

- a) Matchmaker must prioritize the fair play of the competition and consider the preservation of health and longevity of the athlete.
- b) Combined divisions will not be considered a specific belt division match, rather, a match up division.
- c) Combined divisions must abide by the competition rules and time of the youngest and/or lower belt level competitor.







50.2 Kid Belt Divisions for Special Events in GI and No GI competition are as follows:

Skill Level Group	Kid Belt Group	Belt	Belt Sample	Age Group
Beginner	White belt group	White		Any
Intermediate	Gray / Yellow Belt group	Gray/White		4-15
		Solid Gray		5-15
		Gray/Black		6-15
		Yellow/White		7-15
		Solid Yellow		8-15
		Yellow/Black		9-15
Advanced	Orange / Green Belt group	Orange/White		10-15
		Solid Orange		11-15
		Orange/Black		12-15
		Green/White		13-15
		Solid Green		14-15
		Green/Black		15-15

50.3 Kid Weight Divisions for Special Events shall be determined by the Matchmaker and should abide by the guidelines identified in Article 50.1

50.4 Adult Belt Divisions for Special Events for Men and Women in GI and No GI competition are as follows:

Skill Level Group	Adult Belt	Belt Sample	Age Group
Beginner	White Belt		Any
Intermediate	Blue/Purple Belts		16 & up
			
Advanced	Brown /Black Belts		18 & up
			



50.5 Adult Weight Divisions for Special Events for Men and Women in GI and No GI competitions are as follows:

WEIGHT/PESO	MALE ADULT		FEMALE ADULT	
	MASCULINO ADULTO		FEMININO ADULTO	
	GI	No GI	GI	No GI
ROOSTER	127.5 lbs	123.5 lbs	107 lbs	103 lbs
	57.8 kg	56 kg	48.5 kg	46.7 kg
FEATHER +	154 lbs	150 lbs	135 lbs	131 lbs
	69.9 kg	68 kg	61.2 kg	59.4 kg
LIGHT MIDDLE	181 lbs	177 lbs	165 lbs	161 lbs
	82.1 kg	80.3 kg	74.8 kg	73 kg
LIGHT HEAVY	207.5 lbs	203.5 lbs	Over 180 lbs	Over 161 lbs
	94.1 kg	92.3 kg	Acima de 81.6 kg	Acima de 73 kg
HEAVY +	Over 207 lbs	Over 203.5 lbs		
	Acima de 94.1 kg	Acima de 92.3 kg		

50.6 Competitors in Special Events shall wear one of the two competition belts shown below, per the following guidelines:

- Competitor 1 will wear the green and yellow belt for GI or ankle band for No GI competition.
- Competitor 2 will wear the white and blue belt for GI or ankle band for No GI competition.



Competitor 1

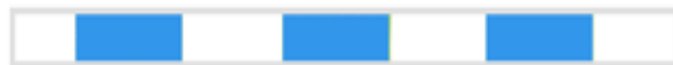

Competitor 2





## Article 51 Protests

51.1 If there is a concern on a decision made by a referee or scorekeeper in regards to points that will assist in determining the winner, an illegal move used during the match, or misidentifying an athlete, the appointed professor must inform the Referee Director or Mat Referee immediately following the match that it is their intent to protest the match so that a hold can be placed on the bracket and corrections made immediately. The guidelines for protest and deliberation are as follows:

- a) The competitor and/or professor are able to protest the action immediately after the match by addressing their concern to the Mat Referee and/or Referee Director.
- b) The Referee Director will assess the issue of protest, hear the opinions of the competitor, referee, and/or professor, and watch video footage if applicable, to determine validity of issue.
- c) Errors in determining match results such as mistakes in calculating the match score or misidentifying an athlete shall in some cases result in the decision being reversed or the match being continued from a specific point in the match.
- d) Error in application of rules such as when the mat referee has made a clear error in applying the competition rules, the outcome of the error shall be corrected.
- e) When an athlete or professor interrupts a match to protest an issue and the referee director reviewing the video footage determines that the protest was invalid, the athlete protesting may be disqualified.
- f) The Referee Director will assist in making the necessary change if necessary. No change will be made if the bracket has already moved on.
- g) The decision of the Referee Director will be final and there will be no means of further appeal.

51.2 In the case that the bracket has moved on prior to an athlete or professor protesting an issue and it is determined that at that point no change can be made the appointed professor representing the athlete may file a written protest to the Referee Director at the tournament or may submit the protest form via email to the federation. The protest must



be submitted on the official protest form, filed within a reasonable period of time, and may include video footage for review. The federation will review written protests to further educate referees on rules or match situations during training.

This version of the Sport Jiu-Jitsu International Federation Rules and Regulations was last updated on January 1, 2026 by the SJJIF. Jiu- Jitsu is constantly evolving as a sport and this book of rules and regulations will be updated and changed to reflect that. The most current edition of this document is available at [www.sjjif.org](http://www.sjjif.org)







**SJJIF**

SPORT JIU-JITSU INTERNATIONAL FEDERATION

**RULEBOOK**

RULES & REGULATIONS